



# FLECK 5800 LXT DOWNFLOW/UPFLOW SERVICE MANUAL



# TABLE OF CONTENTS

JOB SPECIFICATION SHEET .....	2
INSTALLATION .....	3
START-UP INSTRUCTIONS .....	4
CONTROL FEATURES .....	4
CONTROL OPERATION .....	5
MASTER PROGRAMMING MODE .....	6
VIEWING DIAGNOSTIC DATA.....	8
PROGRAM LOCK .....	8
TROUBLESHOOTING.....	9
POWERHEAD ASSEMBLY.....	10
5800 CONTROL VALVE ASSEMBLY .....	11
METER ASSEMBLY - P/N 60626 .....	12
BYPASS VALVE ASSEMBLY (METAL).....	12
BYPASS VALVE ASSEMBLY (PLASTIC).....	13
2310 SAFETY BRINE VALVE .....	13
WATER CONDITIONER FLOW DIAGRAMS .....	14
DIMENSIONAL DRAWINGS.....	16
INJECTOR FLOW DATA.....	17

The chart below is for dealer use only. Use this information to configure the system to suit the application. The 5800 control will use the settings to calculate cycle times.

Tank Diameter	Resin Volume		Injector Size	BLFC Size
	US (FT <sup>3</sup> )	Metric (Liters)		
8	0.75	20	#000	0.125
9		25	#000	0.125
9	1.00	30	#000	0.125
10	1.25	35	#00	0.125
10	1.50	40	#00	0.125
12		45	#00	0.125
12	1.75	50	#00	0.125
12	2.00	55	#0	0.25
13		60	#0	0.25
13	2.25	65	#0	0.25
14	2.50	70	#1	0.25
14		75	#1	0.25
14	2.75	80	#1	0.25
14	3.00	85	#1	0.25
14	3.25	90	#2	0.50
14		95	#2	0.50
14	3.50	100	#2	0.50
16	3.75	105	#3	0.50
16		110	#3	0.50
16	4.00	115	#3	0.50

**IMPORTANT PLEASE READ:**

- The information, specifications and illustrations in this manual are based on the latest information available at the time of printing. The manufacturer reserves the right to make changes at any time without notice.
- This manual is intended as a guide for service of the valve only. System installation requires information from a number of suppliers not known at the time of manufacture. This product should be installed by a plumbing professional.
- This unit is designed to be installed on potable water system only.
- This product must be installed in compliance with all state and municipal plumbing and electrical codes. Permits may be required at the time of installation.
- It is established that when daytime water pressure exceeds 80 psi (5.5 bar), the maximum pressure rating of 125 psi (8.6 bar) can be exceeded. A pressure regulator must be installed on this system or warranty is voided.
- Do not install the unit where temperatures may drop below 32°F (0°C) or above 125°F (52°C).
- Do not place the unit in direct sunlight. Black units will absorb radiant heat increasing internal temperatures.
- Do not strike the valve or any of the components.
- Warranty of this product extends to manufacturing defects. Misapplication of this product may result in failure to properly condition water, or damage to product.
- A prefilter should be used on installations in which free solids are present.
- In some applications local municipalities treat water with Chloramines. High Chloramine levels may damage valve components.
- Correct and constant voltage must be supplied to the controller to maintain proper function.

## JOB SPECIFICATION SHEET

Job Number: \_\_\_\_\_

Model Number: \_\_\_\_\_

Water Hardness: \_\_\_\_\_ ppm or gpg

Capacity Per Unit: \_\_\_\_\_

Mineral Tank Size: \_\_\_\_\_ Diameter: \_\_\_\_\_ Height: \_\_\_\_\_

Salt Setting per Regeneration: \_\_\_\_\_

Regenerant Flow:      Upflow      Downflow

**1. Meter Size:**

A. 3/4" Paddle Wheel (Not Used)

B. 3/4" Turbine

C. 1" Paddle Wheel (Not Used)

D. 1" Turbine (Not Used)

E. 1-1/2" Electronic Inline Plastic Turbine (Not Used)

F. 1-1/2" Paddle Wheel (Not Used)

G. 2" Paddle Wheel (Not Used)

H. Generic \_\_\_\_\_ Pulse Count \_\_\_\_\_ Meter Size \_\_\_\_\_

**2. System Type:**

A. System #4: 1 Tank, 1 Meter, Immediate, or Delayed Regeneration

B. System #4: Time Clock

**3. Control Program Settings:**

A. Backwash: \_\_\_\_\_ Minutes

B. Brine and Slow Rinse: \_\_\_\_\_ Minutes

C. Rapid Rinse: \_\_\_\_\_ Minutes

D. Brine Tank Refill: \_\_\_\_\_ Minutes

E. Pause Time: \_\_\_\_\_ Minutes

F. Second Backwash: \_\_\_\_\_ Minutes

**4. Drain Line Flow Control:** \_\_\_\_\_ gpm

**5. Brine Line Flow Control:** \_\_\_\_\_ gpm

**6. Injector Size#:** \_\_\_\_\_

## INSTALLATION

### Water Pressure

A minimum of 20 psi (1.4 bar) of water pressure is required for the regeneration valve to operate effectively.

### Electrical Facilities

An uninterrupted alternating current (120 VAC) supply is required. The control uses a transformer to supply 12 VDC. Please make sure your voltage supply is compatible with your unit before installation.

### Existing Plumbing

Condition of existing plumbing should be free from lime and iron buildup. Piping that is built up heavily with lime and/or iron should be replaced. If piping is clogged with iron, a separate iron filter unit should be installed ahead of the water softener.

### Location Of Softener And Drain

The softener should be located close to a drain to prevent air breaks and back flow.

### Outdoor Locations

When the water conditioning system is installed outdoors, several items must be considered.

- Moisture — The system is not designed to withstand extreme humidity or water spray from below. Examples are: constant heavy mist, near corrosive environment, upwards spray from sprinkler.

**CAUTION** This unit is for dry location use only unless used with a Listed Class 2 power supply suitable for outdoor use.

- Direct Sunlight — The materials used will fade or discolor over time in direct sunlight. The integrity of the materials will not degrade to cause system failures. If it is necessary to locate the system in direct sunlight, a protective outdoor cover (P/N 61882) over the valve and controller is necessary.
- Insects — If installing in an environment that may expose the system to insects or other small animals, a protective cover is required. The protective outdoor cover (P/N 61882) has been designed to keep all but the smallest insects out of the critical areas. The cover should be installed securely in place.

### Bypass Valves

Always provide for the installation of a bypass valve if unit is not equipped with one.

**CAUTION** Water pressure is not to exceed 125 psi (8.6 bar), water temperature is not to exceed 110°F (43°C), and the unit cannot be subjected to freezing conditions.

**WARNING:** The system must be depressurized before removing any connections for servicing.

### Installation Instructions

1. Place the softener tank where you want to install the unit. Make sure the unit is level and on a firm base.
2. During cold weather, the installer should warm the valve to room temperature before operating.
3. All plumbing should be done in accordance with local plumbing codes. The pipe size for a residential drain line should be a minimum of 1/2" (13 mm). Backwash flow rates in excess of 7 gpm (26.5 Lpm) or drain line length in excess of 20' (6 m) require 3/4" (19 mm) drain line. Commercial drain lines should be the same size as the drain line flow control.

**NOTE:** The tank should have the distributor tube installed and have the proper amount of regenerant in place.

4. Refer to the dimensional drawing for cutting height of the distributor tube. If there is no dimensional drawing, cut the distributor tube flush with the top of the tank.
5. Lubricate the distributor O-ring seal and tank O-ring seal. Place the main control valve on tank. Note: Only use silicone lubricant.
6. Soldering of joints near the drain port must be done prior to connecting the Drain Line Flow Control fitting (DLFC). Leave at least 6" (15 cm) between the DLFC and solder joints when soldering pipes that are connected on the DLFC. Failure to do this could cause interior damage to the DLFC.
7. PTFE plumbing tape is the only sealant to be used on the drain fitting.
8. Make sure that the floor is clean beneath the salt storage tank and that the tank is level.
9. Place approximately 1" (25 mm) of water above the grid plate. If a grid is not utilized, fill to the top of the air check (Figure 1) in the salt tank. Do not add salt to the brine tank at this time.

**CAUTION** If grid plate is used, cut air check height even with grid plate. This is critical on 6", 7", 8" and 9" tanks. The brine refill water must come above the grid plate and make contact with the salt.

10. On units with a bypass, place in bypass position. Turn on the main water supply. Open a cold soft water tap nearby and let run a few minutes or until the plumbing is free from foreign material (usually solder) that may have resulted from the installation. Once clean, close the water tap.
11. Slowly place the bypass in service position and let water flow into the mineral tank. When water flow stops, slowly open a cold water tap nearby and let water run until the air is purged from the unit.
12. Plug the transformer into an electrical outlet.

**NOTE:** All electrical connections must be connected according to local codes. Be certain the outlet is uninterrupted.

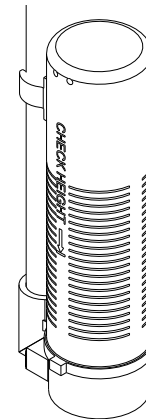

60002 Rev E

Figure 1 Residential Air Check Valve

### Electrical Connection

The controller operates on 12-volt DC power supply. This requires use of the supplied power adapter included with your system.

**NOTE:** The power source should be constant. Be certain the AC adapter is not on a switched outlet. Power interruptions longer than 8 hours may cause the controller to lose the time setting. When power is restored, the time setting must then be re-entered.

## START-UP INSTRUCTIONS

The water softener should be installed with the inlet, outlet, and drain connections made in accordance with the manufacturer's recommendations, and to meet applicable plumbing codes.

1. Program the valve control according to instructions shown in this manual.
2. Start an immediate regeneration by holding the Extra Cycle button for five seconds. Position the valve to backwash. Ensure the drain line flow remains steady for 10 minutes or until the water runs clear.
3. Position the valve to the brine / slow rinse position. Ensure the unit is drawing water from the brine tank (this step may need to be repeated).
4. Position the valve to the rapid rinse position. Check the drain line flow, and run for five minutes or until the water runs clear.
5. Position the valve to the start of the brine tank fill cycle. Ensure water goes into the brine tank at the desired rate. The brine valve drive cam will hold the valve in this position to fill the brine tank for the first regeneration.
6. Replace control cover.
7. Put salt in the brine tank.

**NOTE: Do not use granulated or rock salt.**

## CONTROL FEATURES

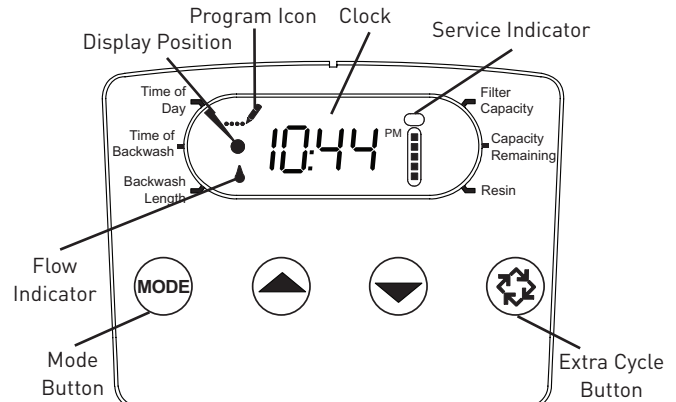

Figure 2

### Features of the LXT:

- Power backup that continues to keep time and the passage of days for a minimum of 8 hours in the event of power failure. During a power outage, the control goes into a power-saving mode. It does not monitor water usage during a power failure, but it does store the volume remaining at the time of power failure.
- Day of the week reserve calculates a reserve for each day based on the past four weeks.
- The Flow Indicator flashes when outlet flow is detected.
- The Service Indicator flashes if a regeneration cycle has been queued.
- A regeneration can be triggered immediately by pressing the Extra Cycle button for five seconds.
- During regeneration, the user can force the control to advance to the next cycle step immediately by pressing the extra cycle button.
- During a regeneration, the display will show the cycle number followed by the time remaining in that cycle.

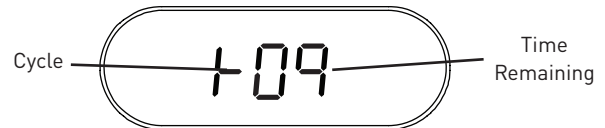

Figure 3

### Setting the Time of Day

1. Press and hold either the Up or Down buttons until the Time of Day icon appears.
2. Adjust the displayed time with the Up and Down buttons.
3. When the desired time is set, press the Extra Cycle button to resume normal operation. The unit will also return to normal operation after five seconds if no buttons are pressed.



Figure 4

### Queueing a Regeneration

1. Press the Extra Cycle button. The service icon will flash to indicate that a regeneration is queued.
2. To cancel a queued regeneration, press the Extra Cycle button.

### Regenerating Immediately

Press and hold the Extra Cycle button for five seconds.

## CONTROL OPERATION

---

### Meter Delayed Control

A Meter Delayed control measures water usage. The system regenerates at the programmed regeneration time after the calculated system capacity is depleted. The control calculates the system capacity by dividing the unit capacity by the feed water hardness and subtracting the reserve. A Meter Delayed control will also start a regeneration cycle at the programmed regeneration time if a number of days equal to the regeneration day override passes before water usage depletes the calculated system capacity.

### Control Operation During Regeneration

During regeneration, the control displays the current regeneration step number the valve has reached, and the time remaining in that step. Four dashes are displayed until the valve reaches the next regeneration step position. Once all regeneration steps are complete the valve returns to service and resumes normal operation.

The meter and time clock controls will use and display the following cycles:

1. Backwash
2. Brine/Slow Rinse
3. Rapid Rinse
4. Brine Tank Refill

The filter controls will use and display the following cycles:

1. Backwash
2. Rapid Rinse

Pressing the Extra Cycle button during a regeneration cycle immediately advances the valve to the next cycle step position and resumes normal step timing.

### Control Operation During Programming

The control only enters Program Mode with the valve in service. While in Program Mode, the control continues to operate normally monitoring water usage and keeping all displays up to date. Control programming is stored in memory permanently, and does not rely on battery backup power.

### Manually Initiating a Regeneration

1. When the control is in service, press the Extra Cycle button for five seconds on the main screen.
2. The control advances to Regeneration Cycle Step #1 (backwash), and begins programmed time count down.
3. Press the Extra Cycle button once to advance valve to Regeneration Cycle Step #2 (brine draw and slow rinse).
4. Press the Extra Cycle button once to advance valve to Regeneration Cycle Step #3 (rapid rinse).
5. Press the Extra Cycle button once to advance valve to Regeneration Cycle Step #4 (brine refill).
6. Press the Extra Cycle button once more to advance the valve back to in service.

**NOTE: If the unit is a filter or upflow, the cycle step order may change.**

**NOTE: A queued regeneration can be initiated by pressing the Extra Cycle button. To clear a queued regeneration, press the Extra Cycle button again to cancel. If regeneration occurs for any reason prior to the delayed regeneration time, the manual regeneration request will be cleared.**

### Control Operation During a Power Failure

The LXT includes integral power backup. In the event of power failure, the control shifts into a power-saving mode. The control stops monitoring water usage. The display and motor shut down, but it continues to keep track of the time and day for a minimum of 12 hours.

The system configuration settings are stored in a non-volatile memory and are stored indefinitely with or without line power.

If power fails while the unit is in regeneration, the control will save the current valve position before it shuts down. When power is restored, the control will resume the regeneration cycle from the point where power failed.

**CAUTION** If power fails during a regeneration cycle, the valve will remain in its current position until power is restored. The valve system should include all required safety components to prevent overflows resulting from a power failure during regeneration.

The control will not start a new regeneration cycle without line power. If the valve misses a scheduled regeneration due to a power failure, it will queue a regeneration. Once power is restored, the control will initiate a regeneration cycle the next time that the Time of Day equals the programmed regeneration time. Typically, this means that the valve will regenerate one day after it was originally scheduled. If the treated water output is important and power interruptions are expected, the system should be set up with a sufficient reserve capacity to compensate for regeneration delays.

# MASTER PROGRAMMING MODE

**CAUTION** Before entering Master Programming, please contact your local professional water dealer.

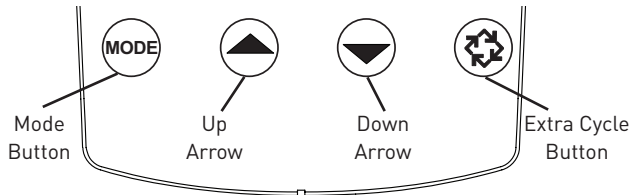

Figure 5

- Press the Mode button to cycle through programming options.
- Set time of day by holding the Up or Down arrow.
- Hold the Extra Cycle button until the Program icon disappears to save the current time.
- When the control is first plugged in the display position will point to Resin.
- Hold the Up button to begin programming.
- Use the Up or Down arrow to adjust the amount of resin in your tank. English resin range is 0.25-4.0 CuFt. Metric resin range is 5-100 liters. Select F for filter.
- Hold the Extra Cycle button to save the resin volume.

**NOTE:** The resin volume setting will only be displayed at first power-up or when the user manually advances the Mode button to Resin.

## Meter Downflow/Upflow

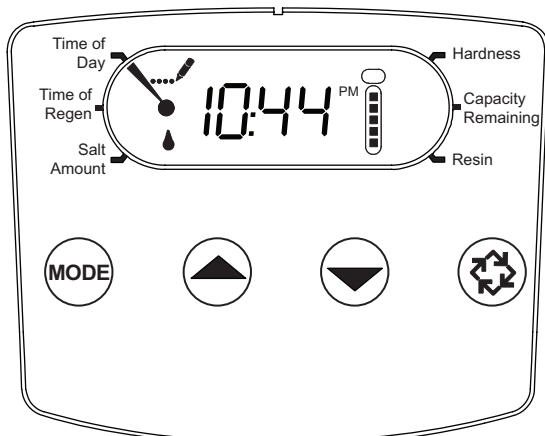

Figure 6

1. Press the Mode button to advance to Time of Regen. Push the Up or Down arrow to adjust the time of regeneration.
2. Press the Mode button again to advance to Salt Amount. Press the Up or Down arrow to adjust your salt dosage. English salt dosage range is 3-18 lbs. Metric salt dosage range is 50-290 grams per liter.
3. Press the Mode button again to advance to Hardness. Press the Up or Down arrow to adjust the setting to the untreated water hardness. English hardness range is 3-200 gpg. Metric hardness range is 30-200 mg/L.
4. Hold the Extra Cycle button until the Program icon disappears to save your programming.
5. Press the Mode button again to advance to Capacity Remaining. This is the amount of gallons the unit can treat. This is not adjustable.
6. If you are just changing one program step, hold the Extra Cycle button until the Program icon disappears to save your changes. If you do not hold the Extra Cycle button until the Program icon disappears your changes will not be saved.

**NOTE:** This unit has a day of the week reserve. It calculates a reserve for each day of the week based on the past four weeks.

## Setting Day Override

The Day Override setting specifies the maximum number of days between regeneration cycles. A metered system will regenerate after the number of days set in day override regardless of usage if the days since last regeneration cycle equal the day override setting.

1. Press the Mode button to advance to Salt Amount. Hold the Up button to enter Master Programming.
2. Hold the Mode and Extra Cycle buttons to enter the Day Override setting. Press the Up or Down arrow to adjust the maximum number of days between regeneration cycles. A value of zero turns the setting off.
3. Hold the Extra Cycle button to save the day override setting.

**NOTE:** If Day Override has a value other than zero, it will appear as a programming option when pressing the Mode button, and can be adjusted by holding the Up button.

## Time Clock Downflow/Upflow

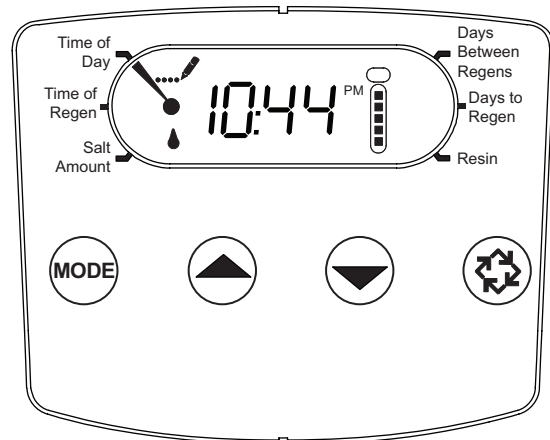

Figure 7

1. Press the Mode button to advance to Time of Regen. Push the Up or Down arrow to adjust the time of regeneration.
2. Press the Mode button again to advance to Salt Amount. Press the Up or Down arrow to adjust your salt dosage. English salt dosage range is 3-18 lbs. Metric salt dosage range is 50-290 grams per liter.
3. Press the Mode button again to advance to Days Between Regens. Range is 1-30 days.
4. Hold the Extra Cycle button until the Program icon disappears to save your programming.
5. Press the Mode button again to advance to Days to Regen. This is not adjustable.
6. If you are just changing one program step, hold the Extra Cycle button until the Program icon disappears to save your changes. If you do not hold the Extra Cycle button until the Program icon disappears, your changes will not be saved.

## MASTER PROGRAMMING MODE *continued*

### Filter Meter

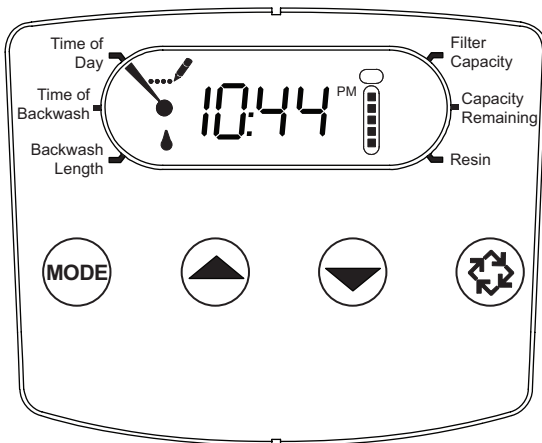

Figure 8

1. Press the Mode button to advance to Time of Backwash. Push the Up or Down arrow to adjust the time of backwash.
2. Press the Mode button again to advance to Backwash Length. Press the Up or Down arrow to adjust your backwash length. Range is 1-30 minutes.
3. Press the Mode button again to advance to Filter Capacity. Press the Up or Down arrow to adjust the setting for filter capacity. English capacity range is 100-90,000 gallons. Metric capacity range is 1-900 cubic meters.
4. Press the Mode button again to advance to Day Override. Press the Up or Down arrow to adjust the the maximum number of days between regeneration cycles.
5. Hold the Extra Cycle button until the Program icon disappears to save your programming.
6. Press the Mode button again to advance to Capacity Remaining. This is not adjustable.
7. If you are just changing one program step, hold the Extra Cycle button until the Program icon disappears to save your changes. If you do not hold the Extra Cycle button until the Program icon disappears your changes will not be saved.

**NOTE: This unit has a day of the week reserve. It calculates a reserve for each day of the week based on the past four weeks.**

### Setting Day Override

The Day Override setting specifies the maximum number of days between regeneration cycles. A metered system will regenerate after the number of days set in day override regardless of usage if the days since last regeneration cycle equal the day override setting.

1. Press the Mode button to advance to Backwash Length. Hold the Up button to enter Master Programming.
2. Hold the Mode and Extra Cycle buttons to enter the Day Override setting. Press the Up or Down arrow to adjust the maximum number of days between regeneration cycles. A value of zero turns the setting off.
3. Hold the Extra Cycle button to save the day override setting.

**NOTE: If Day Override has a value other than zero, it will appear as a programming option when pressing the Mode button, and can be adjusted by holding the Up button.**

### Filter Time Clock

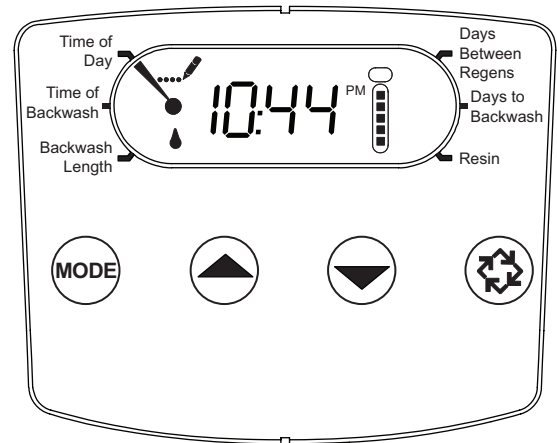

Figure 9

1. Press the Mode button to advance to Time of Backwash. Push the Up or Down arrow to adjust the time of backwash.
2. Press the Mode button again to advance to Backwash Length. Press the Up or Down arrow to adjust your backwash length. Range is 1-30 minutes.
3. Press the Mode button again to advance to Days Between Regens. Range is 1-30 days.
4. Hold the Extra Cycle button until the Program icon disappears to save your programming.
5. Press the Mode button again to advance to Days to Backwash. This is not adjustable.
6. If you are just changing one program step, hold the Extra Cycle button until the Program icon disappears to save your changes. If you do not hold the Extra Cycle button until the Program icon disappears, your changes will not be saved.

## VIEWING DIAGNOSTIC DATA

Demand - US Units	
Diagnostic Code	Description
H1	Displays the days since last regeneration, 0-30.
H2	Displays the current flow rate, gallons per minute.
H3	Displays the current day of week, 1-7.
H4	Displays the total volume of water treated by the unit for the current day in gallons.
H5	Displays the total volume of water used since the last regeneration in gallons.
H6	Displays the total volume of water used in gallons since the unit was last reset.
H7	Displays the software version. Version number of software. D = Downflow U = Upflow
A1	Displays the average water usage for day 1, in gallons.
A2	Displays the average water usage for day 2, in gallons.
A3	Displays the average water usage for day 3, in gallons.
A4	Displays the average water usage for day 4, in gallons.
A5	Displays the average water usage for day 5, in gallons.
A6	Displays the average water usage for day 6, in gallons.
A7	Displays the average water usage for day 7, in gallons.

Demand - Metric Units	
Diagnostic Code	Description
H1	Displays the days since last regeneration, 0-30.
H2	Displays the current flow rate, liters per minute.
H3	Displays the current day of week, 1-7.
H4	Displays the total volume of water treated by the unit for the current day, in cubic meters.
H5	Displays the total volume of water used since the last regeneration, in cubic meters.
H6	Displays the total volume of water used in cubic meters since the unit was last reset.
H7	Displays the software version. Version number of software. D = Downflow U = Upflow
A1	Displays the average water usage for day 1, in cubic meters.
A2	Displays the average water usage for day 2, in cubic meters.
A3	Displays the average water usage for day 3, in cubic meters.
A4	Displays the average water usage for day 4, in cubic meters.
A5	Displays the average water usage for day 5, in cubic meters.
A6	Displays the average water usage for day 6, in cubic meters.
A7	Displays the average water usage for day 7, in cubic meters.

Time Clock	
Diagnostic Code	Description
H1	Displays the days since last regeneration, 1-7.
H7	Displays the software version. Version number of software. D = Downflow U = Upflow

**NOTE: English units will be in gallons and metric units will be in liters for all flow rates.**

### Diagnostics View Mode Steps

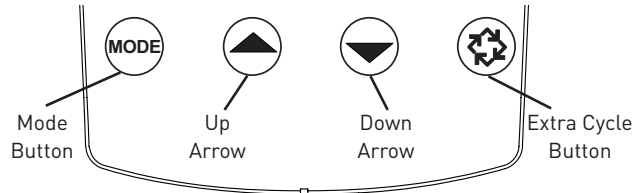

Figure 10

1. To enter the Diagnostics View Mode, press and hold the Mode button and the Up arrow.
2. The display will show the first diagnostic. Press the Up arrow to view the value.
3. Press the Mode button twice to move to the next diagnostic.
4. Press the Up arrow to view the value. Continue in this manner until you have viewed all the diagnostics. The table above shows all diagnostic values.
5. To exit Diagnostics View Mode, hold the Extra Cycle button for five seconds. It will also exit after 30 seconds if no button is pushed.

## PROGRAM LOCK

Each individual parameter may be locked independent of others. When a parameter is locked, the parameter cannot be changed until the lock is removed. Locked parameters are indicated by a lock icon on the display.

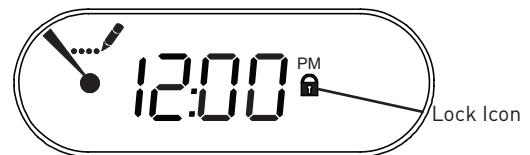

Figure 11

1. To lock a parameter, press and hold the Extra Cycle button and the Down arrow while in Program mode with the parameter to be locked displayed.

**NOTE: Pressing the Extra Cycle button before pressing the Down arrow will ensure that the parameter value will not change while locking the parameter.**

2. The Lock icon will appear on the display, indicating the parameter is locked.
3. Press and hold the Extra Cycle button and the Down arrow while displaying a locked parameter to unlock it.



# TROUBLESHOOTING

## Error Codes

**NOTE: Error codes appear on the In Service display.**

Error Code	Error Type	Cause	Reset and Recovery
---0	Motor Stall /Cam Sense Error	No state changes in the optical sensor are detected for six seconds.	<p>Unplug the unit and plug back in. Allow the control to attempt to find position again.</p> <p>Verify the optical sensor is in place with the wires connected to the circuit board. Verify the motor and drive train components are in good condition and assembled properly. Check the valve and verify that the piston travels freely. Replace/reassemble the various components as necessary.</p> <p>Plug the unit back in and observe its behavior. If the error reoccurs, unplug the unit, put it into bypass and contact technical support.</p>
---1	Motor Run-On Error /Cycle Sense Error	An undesired optical sensor state change occurred.	Non-critical error. Extra optical sensor pulse detected. Press any button to clear the error. Press extra cycle button to advance motor to clear error.
---2	Regen Failure	The system has not regenerated in 30 days.	<p>Perform a Manual Regeneration to reset the error code.</p> <p>If the system is metered, verify that it is measuring flow by running service water and watching for the flow indicator on the display. If the unit does not measure flow, verify that that the day override is set properly, the meter cable is connected properly, and that the meter is functioning properly.</p> <p>Enter Master Programming Mode and verify that the unit is configured as appropriate for the valve configuration. Check that the correct system capacity and meter size has been selected.</p>
---4	Fail Safe Error	Valve has failed to find position in one minute.	Unplug the unit and plug it back in. If error continues, call technical support.
FSEr	Finding Service	Valve is looking for service.	Allow valve to find position.

# POWERHEAD ASSEMBLY

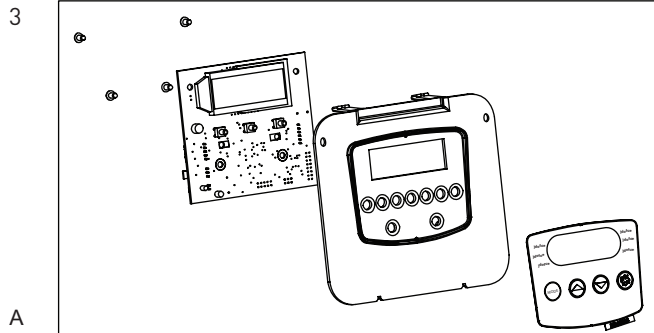
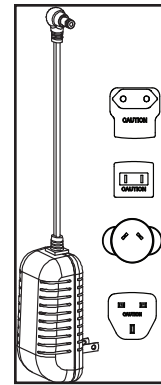
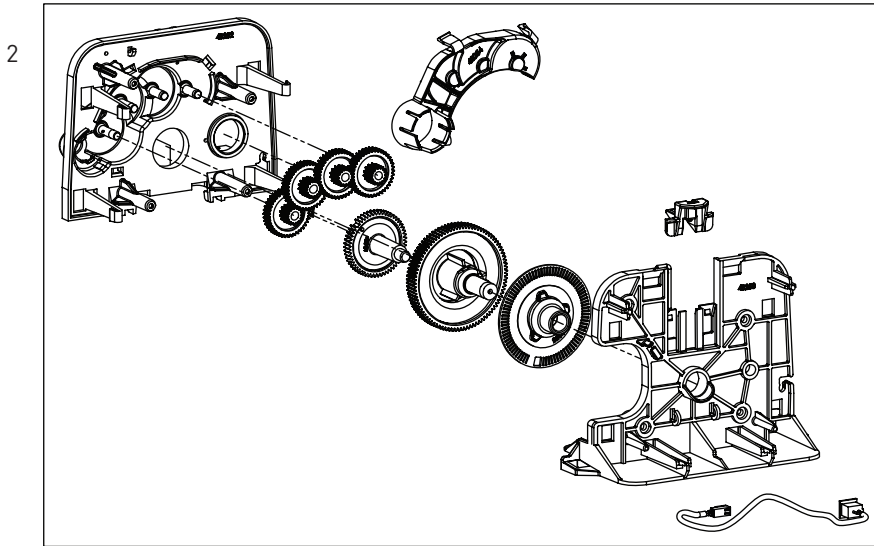
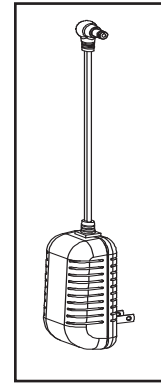
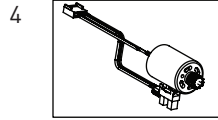
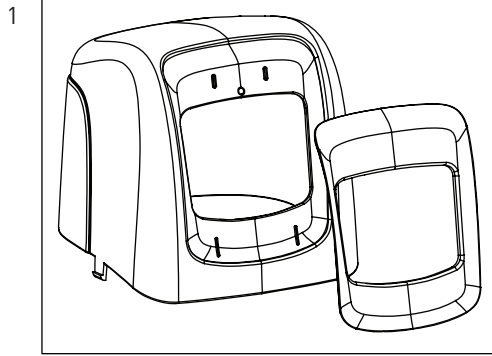

BR61501-5800 Rev A

Item No.	QTY	Part No.	Description
1.....	1.....	61832-00.....	Cover Assembly, Black/Blue
.....	.....	61832-01.....	Cover Assembly, Black/Black
.....	.....	61832-02.....	Cover Assembly, Black/Silver
2.....	1.....	61836.....	Panel Gear Assembly, Upflow/ Downflow
3.....	1.....	* .....	E Timer
4.....	1.....	61835.....	Motor Assembly
5.....	1.....	61882.....	Cover Assembly, Environmental
6.....	1.....	43291.....	Transformer 12V UL
7.....	1.....	43318.....	Transformer, Intl, 12V UL

\*Call your distributor for part number.

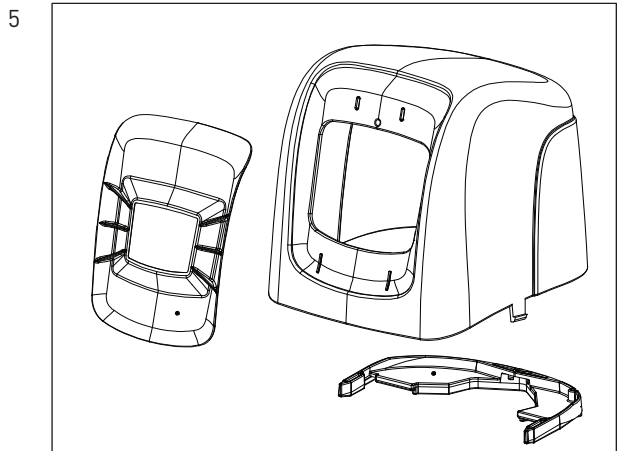

BR61882 Rev B

# 5800 CONTROL VALVE ASSEMBLY

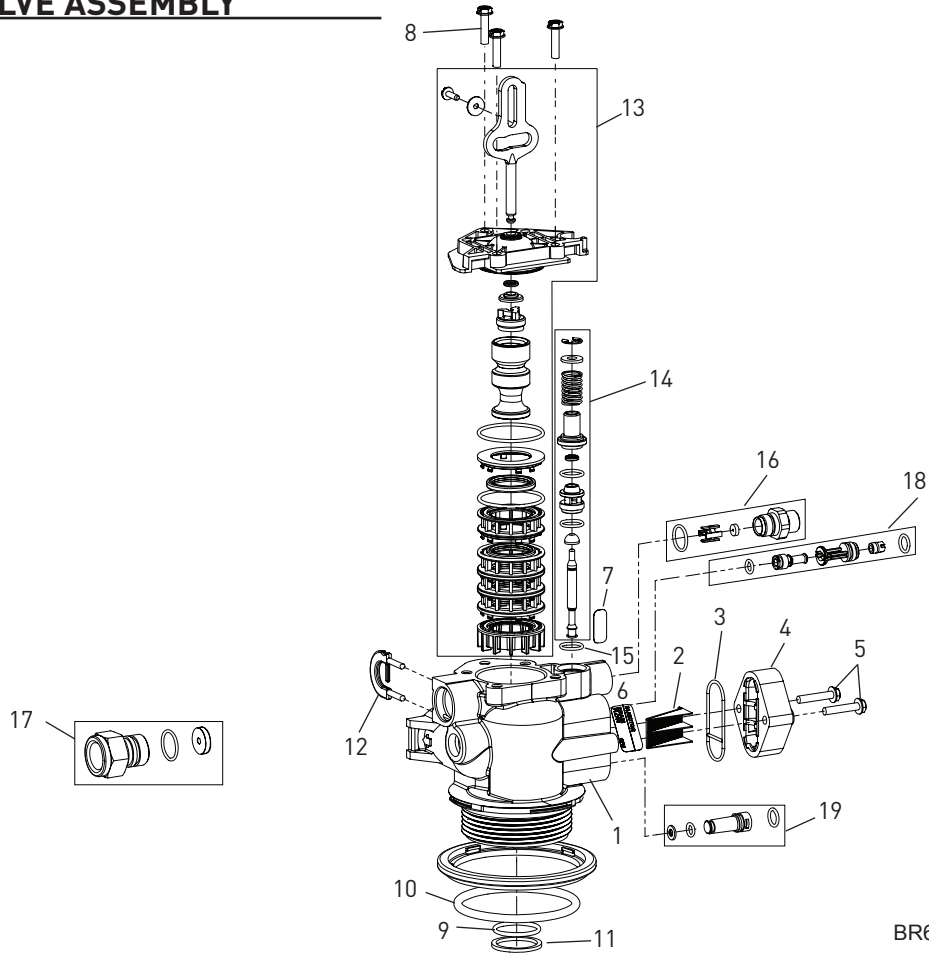

BR61500-5800 Rev A

Item No.	QTY	Part No.	Description
1	1	61857-01	Valve Body Assy, Downflow/Upflow (Includes Items 9, 10, 11, 12)
		61857-20	Valve Body Assy, Mixing, Downflow/Upflow (Includes Items 9, 10, 11, 12)
2	1	18271	Screen Injector, 5000
3	1	40064	Seal Injector
4	1	18277	Cap Injector
		18278-20	Injector Cap Assy, 1610 Regulated, 5000, 20 psi, Black, Upflow
		18278-30	Injector Cap Assy, 1610 Regulated, 5000, 30 psi, Black, Upflow
5	2	18262	Screw, Hex Washer Head, #10-24 x 1.00
6	1	19654	Label, 0.125 gpm Brine Flow
		12128	Label, 0.25 gpm BLFC
		10759	Label, 0.5 gpm 1.5 lbs Salt/Min
		10760	Label, 1.0 gpm 3 lbs Salt/Min
7	1	13333	Label, Injector, Blank
8	3	18261	Screw, Hex Washer Head, #10-24 0.81
9	1	13304	O-ring, -121
10	1	18303-01	O-ring, -336, 560CD
11	1	13030	Retainer, Distributor Tube O-ring
12	1	18312	DLFC Housing Retainer Clip
13		61837	Piston and Seal Kit Assy, Downflow, 5800
		61838	Piston and Seal Kit Assy, Upflow, 5800
14	1	60032	Brine Valve, 4600/5600
15	1	13302	O-ring, -014
16		60022-12	BLFC, 0.125 gpm
		60022-25	BLFC, 0.25 gpm
		60022-50	BLFC, 0.5 gpm
		60022-100	BLFC, 1.0 gpm
17		60705-00	DLFC, Plastic, Blank
		60705-06	DLFC, Plastic, 0.60 gpm
		60705-08	DLFC, Plastic, 0.80 gpm
		60705-10	DLFC, Plastic, 1.0 gpm
		60705-12	DLFC, Plastic, 1.2 gpm
		60705-13	DLFC, Plastic, 1.3 gpm
		60705-15	DLFC, Plastic, 1.5 gpm
		60705-17	DLFC, Plastic, 1.7 gpm
		60705-20	DLFC, Plastic, 2.0 gpm
		60705-24	DLFC, Plastic, 2.4 gpm
		60705-30	DLFC, Plastic, 3.0 gpm
		60705-35	DLFC, Plastic, 3.5 gpm
		60705-40	DLFC, Plastic, 4.0 gpm
		60705-45	DLFC, Plastic, 4.5 gpm
		60705-50	DLFC, Plastic, 5.0 gpm
		60705-60	DLFC, Plastic, 6.0 gpm
		60705-20	DLFC, Plastic, 2.0 gpm
		60705-70	DLFC, Plastic, 7.0 gpm
		60706-8.0	DLFC, AC x 3/4" F, 8 gpm
		60706-9.0	DLFC, AC x 3/4" F, 9 gpm
		60706-10	DLFC, AC x 3/4" F, 10 gpm
		60706-12	DLFC, AC x 3/4" F, 12 gpm
		60706-15	DLFC, AC x 3/4" F, 15 gpm
18		18272-000	Injector Assy, 1610, #000, Brown
		18272-00	Injector Assy, 1610, #00, Violet
		18272-0	Injector Assy, 1610, #0, Red
		18272-1	Injector Assy, 1610, #1, White
		18272-2	Injector Assy, 1610, #2, Blue
		18272-3	Injector Assy, 1610, #3, Yellow
19		18276-01	Injector Assy, Plug, w/O-rings
<b>Not Shown:</b>			
		40947-01	Plug, Brine Valve, w/O-ring, 560CD
		13918-01	BLFC Module Plug Assy, w/O-ring

**NOTE:** In upflow units, the Injector Plug and Injector Assy are put in the reverse holes. In filter units, both injector holes are plugged with 18276-01.

**CAUTION** Excessive side load on piston rod may cause premature damage. If seal/spacer stack is stuck in valve bore during disassembly, rotate stack prior to removal.

## METER ASSEMBLY - P/N 60626

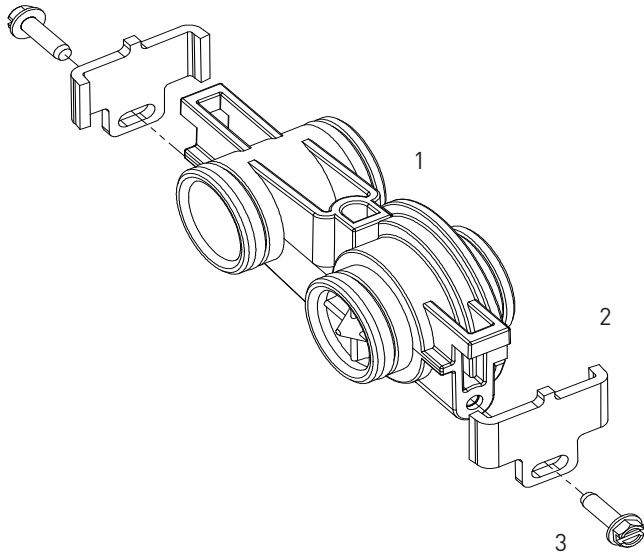

BR60626

Item No.	QTY	Part No.	Description
1.....	1.....	19797 .....	Meter Assy, 3/4" Dual Port, SLP
2.....	2.....	19569 .....	Clip, Flow Meter
3.....	2.....	13314 .....	Screw, Slot Ind Hex, 8-18 x 0.60

**Not Shown:**

- ..... 14613 .....Flow Straightener
- ..... 19791-01.....Meter Cable Assy, Turbine/SXT

## BYPASS VALVE ASSEMBLY (METAL)

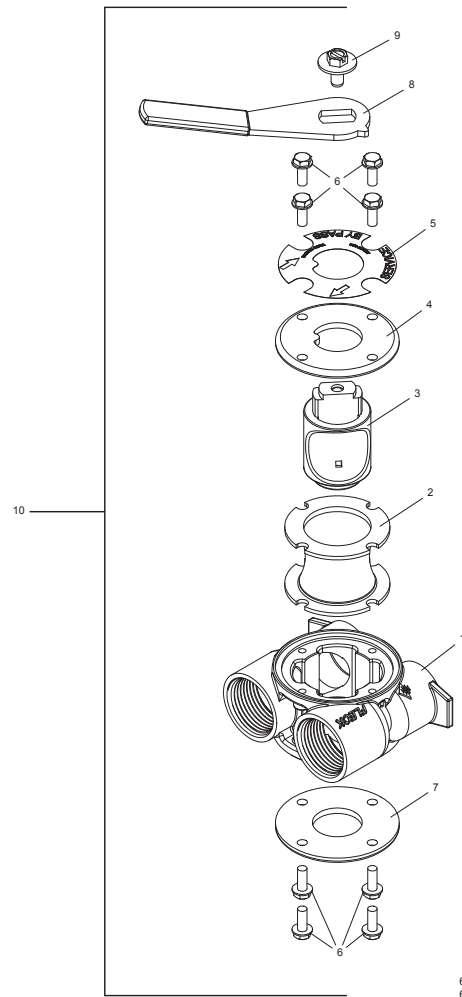

60040SS Rev Y  
60041SS Rev AA

Item No.	QTY	Part No.	Description
1.....	1.....	40614 .....	Bypass Body, 3/4"
		..... 40634 .....	Bypass Body, 1", SS
2.....	1.....	14105 .....	Seal, Bypass, 560CD
3.....	1.....	11972 .....	Plug, Bypass
4.....	1.....	11978 .....	Side Cover
5.....	1.....	13604-01.....	Label
6.....	8.....	15727 .....	Screw, 10-24 x 0.5"
7.....	1.....	11986 .....	Side Cover
8.....	1.....	11979 .....	Lever, Bypass
9.....	1.....	11989 .....	Screw, Hex Head, 1/4-14 x 1.5"
10.....	1.....	60040SS.....	Bypass Valve, 5600, 3/4" NPT Black Grip Lever, SS
		..... 60041SS.....	Bypass Valve, 5600, 1" NPT Black Grip Lever, Stainless Steel

**Not Shown:**

- 2..... 19228-01.....Adapter Assy, Coupling,  
w/O-rings

## BYPASS VALVE ASSEMBLY (PLASTIC)

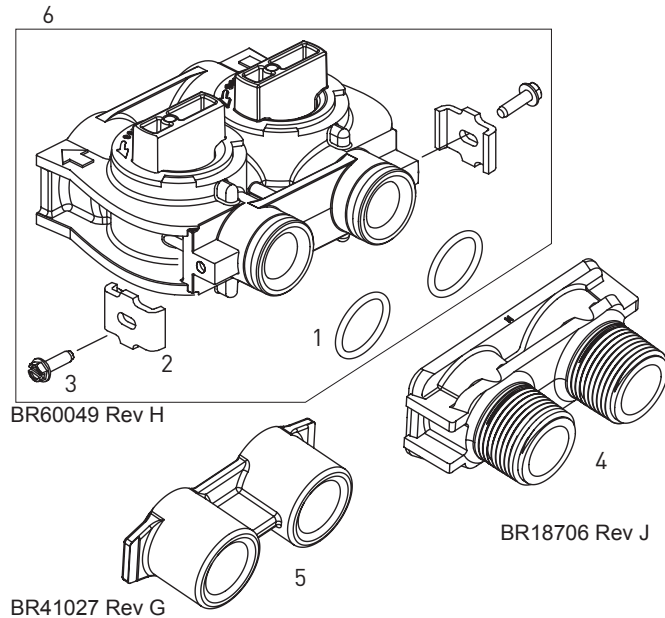

Item No.	QTY	Part No.	Description
1	2	13305	O-ring, -119
2	2	13255	Clip, Mounting
3	2	13314	Screw, Slot Ind Hex, 8-18 x 0.60
4	1	18706	Yoke, 1", NPT, Plastic
		18706-02	Yoke, 3/4", NPT, Plastic
5	1	13708-40	Yoke, 1", Sweat
		13708-45	Yoke, 3/4", Sweat
		19275	Yoke, Angle 90 Deg, 3/4", NPT
		19275-45	Yoke, Angle 90 Deg, 3/4", Sweat
		19620-01	Yoke, Assy, 3/4", R/Angle 90 Deg, w/O-rings, Clips & Screws
		40636	Yoke, 1-1/4", NPT
		40636-49	Yoke, 1-1/4", Sweat
		41027-01	Yoke, 3/4", NPT, Cast, Machined
		41026-01	Yoke, 1", NPT, Cast, Machined, SS
		41026-02	Yoke, 1", BSP, Cast, Machined, SS
		18706-10	Yoke, 1", BSP, Plastic
		41027-02	Yoke, 3/4", BSP, Cast, Machined
		18706-12	Yoke, 3/4", BSP, Plastic
		19620-01	Yoke Assy, 3/4", R/Angle, 90 Deg
6	1	60049	Bypass Plastic

**Not Shown:**

2	19228-01	Adapter Assy, Coupling, w/O-rings
---	----------	-----------------------------------

## 2310 SAFETY BRINE VALVE

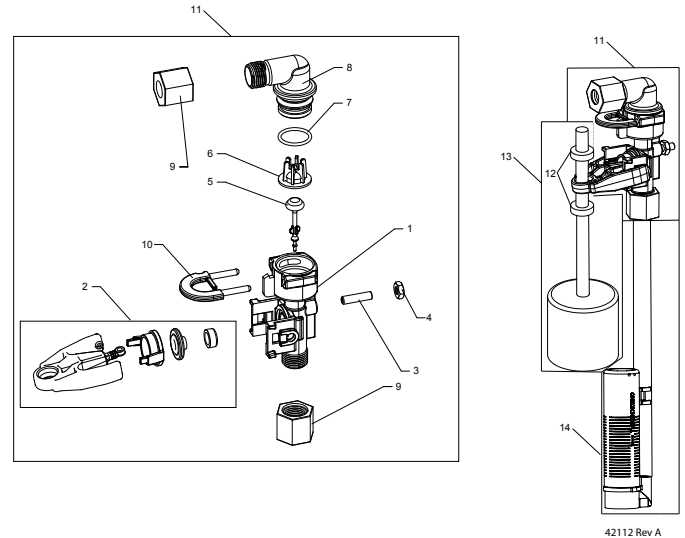

Item No.	QTY	Part No.	Description
1	1	19645	Body, Safety Brine Valve, 2310
2	1	19803	Safety Brine Valve Assy
3	1	19804	Screw, Sckt Hd, Set, 10-24 x 0.75
4	1	19805	Nut, Hex, 10-24, Nylon Black
5	1	19652-01	Poppet Assy, SBV w/O-ring
6	1	19649	Flow Dispenser
7	1	11183	O-ring, -017
8	1	19647	Elbow, Safety Brine Valve
9	2	19625	Nut Assy, 3/8" Plastic
10	1	18312	Retainer, Drain
11	1	60014	Safety Brine Valve Assy, 2310
12	2	10150	Grommet, 0.30 Dia
13	1	60068-10.5	Float Assy, 2310, w/10.5" Rod
		60068-11.5	Float Assy, 2310, w/11.5" Rod
		60068-20	Float Assy, 2310, w/20" Rod
		60068-30	Float Assy, 2310, w/30" Rod
14	1	60002-11.38	Air Check, #500, 11.38" Long
		60002-27	Air Check, #500, 27" Long
		60002-32	Air Check, #500, 32" Long
		60002-34	Air Check, #500, 34" Long
		60002-36	Air Check, #500, 36" Long
		60002-48	Air Check, #500, 48" Long
		60002-26.25	Air Check, #500, 26.25" Long
		60002-33.25	Air Check, #500, 33.25" Long

# WATER CONDITIONER FLOW DIAGRAMS

## Downflow

### 1. Service Position

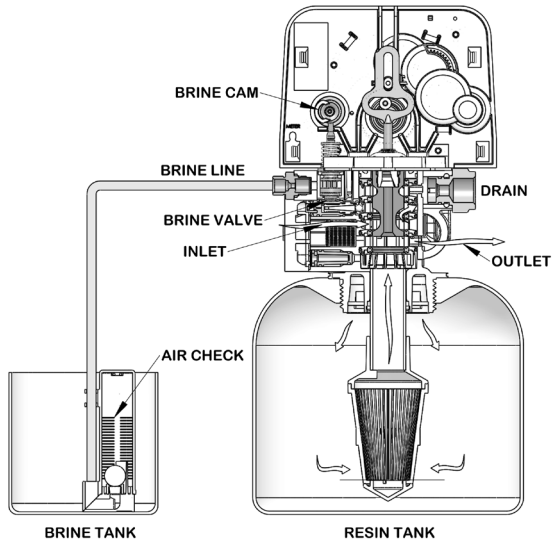

### 4. Rapid Rinse Position

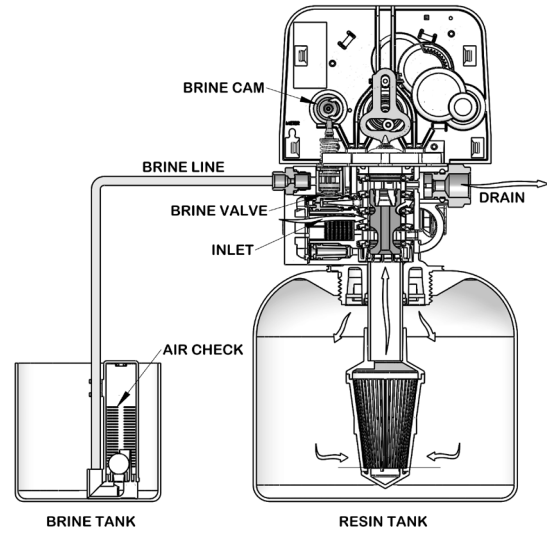

### 2. Backwash Position

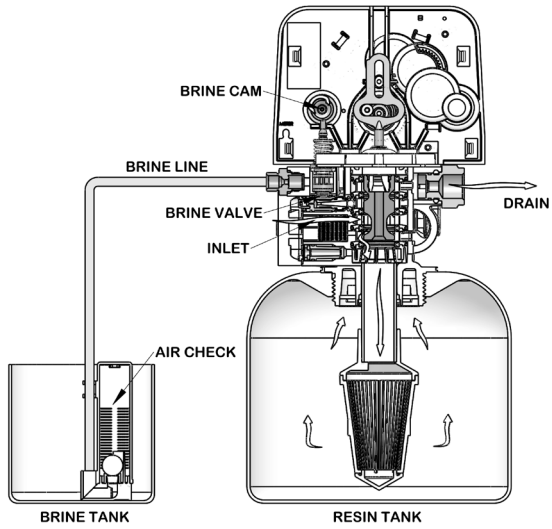

### 5. Brine Tank Refill Position

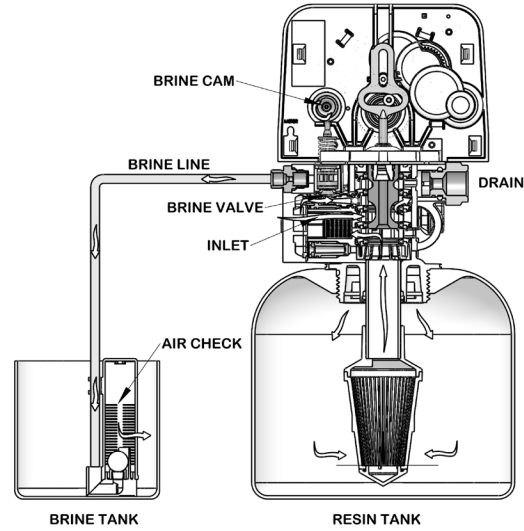

### 3. Brine/Slow Rinse Position

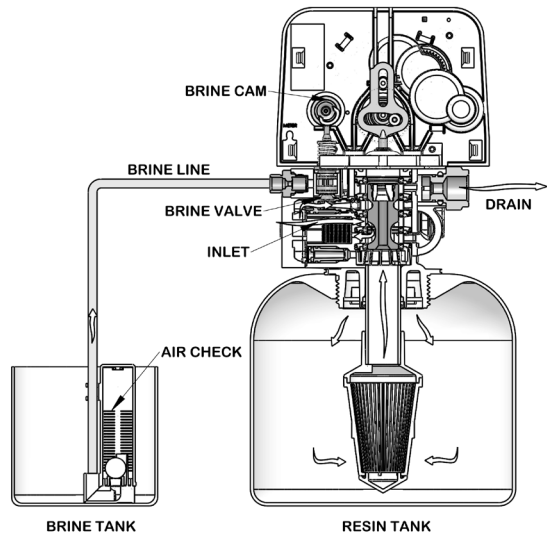

# WATER CONDITIONER FLOW DIAGRAMS

*continued*

## Upflow

1. Service Position

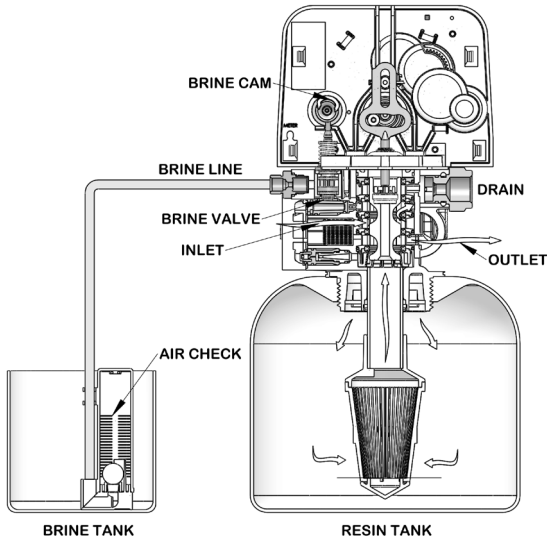

4. Rapid Rinse Position

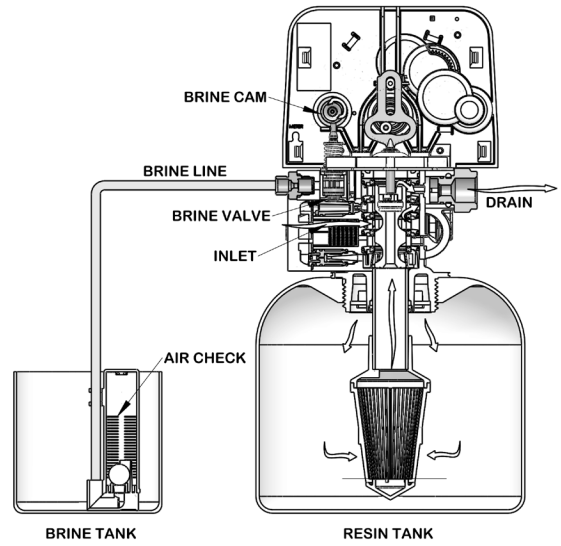

2. Brine/Slow Rinse Position

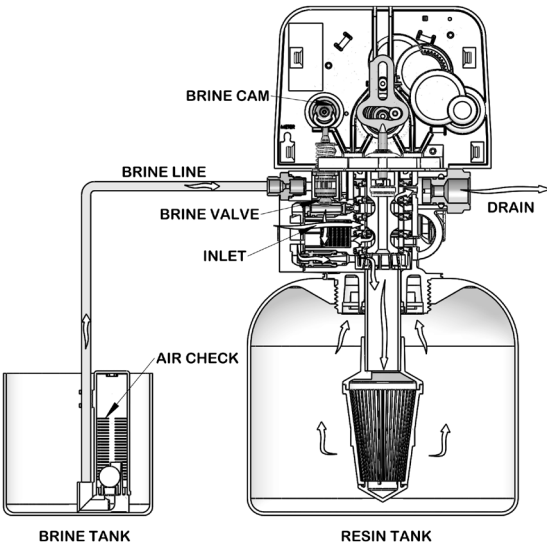

5. Brine Tank Refill Position

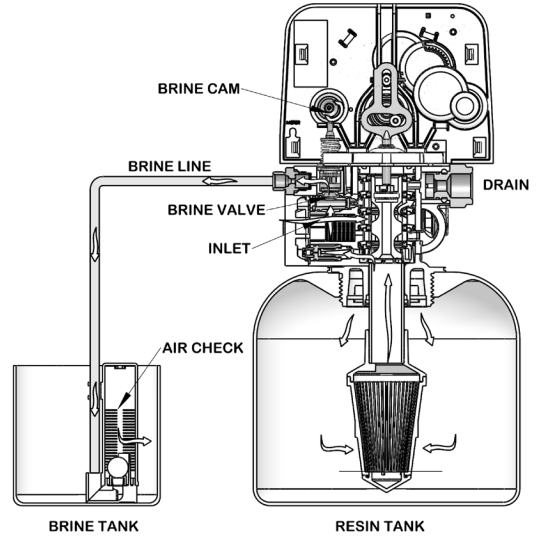

3. Backwash Position

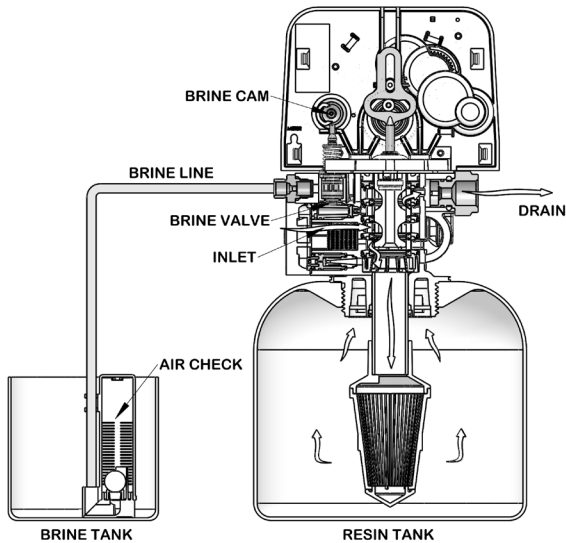

# DIMENSIONAL DRAWINGS

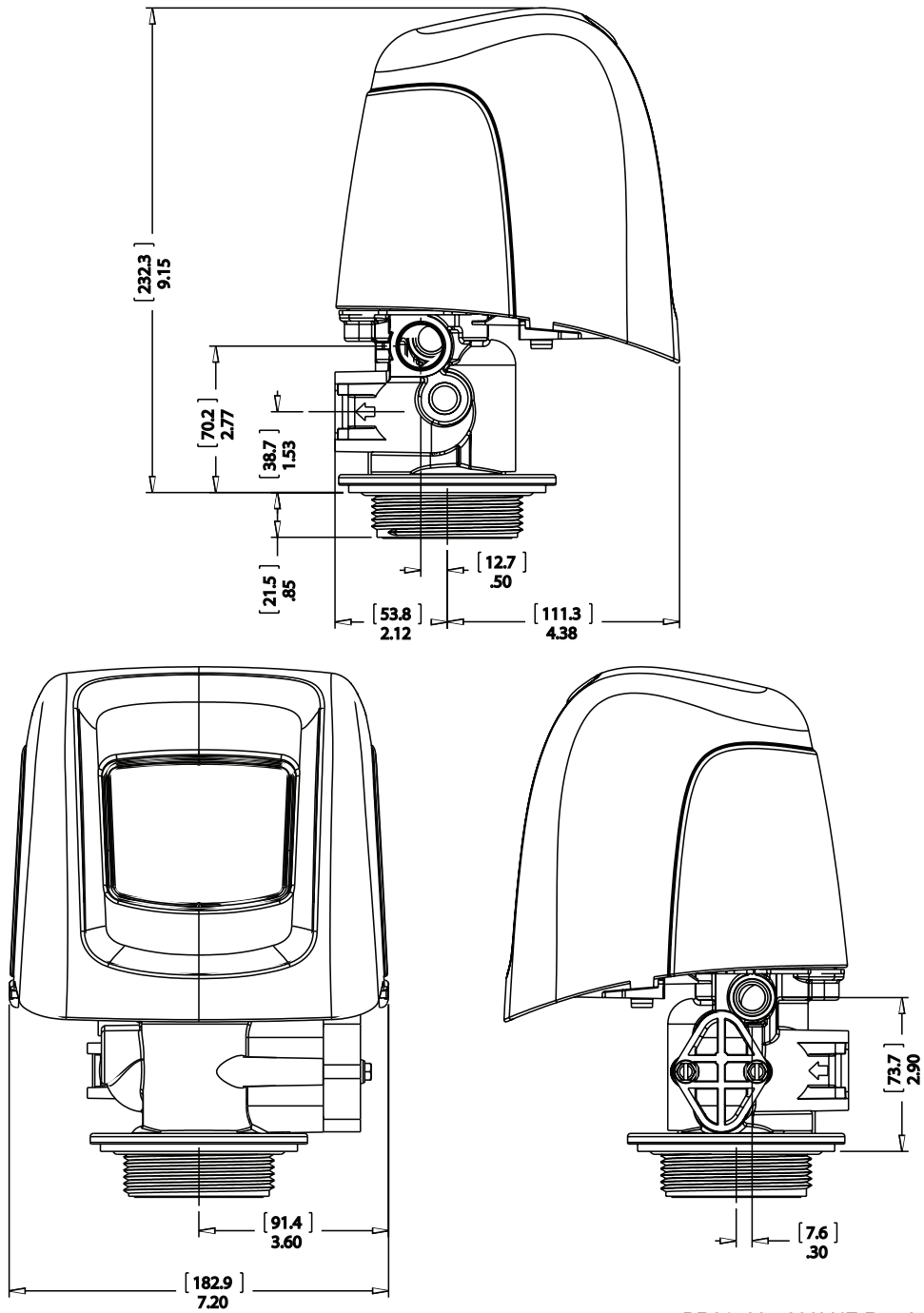

BR61500-5800LNE Rev A



# INJECTOR FLOW DATA

**Injector #000**

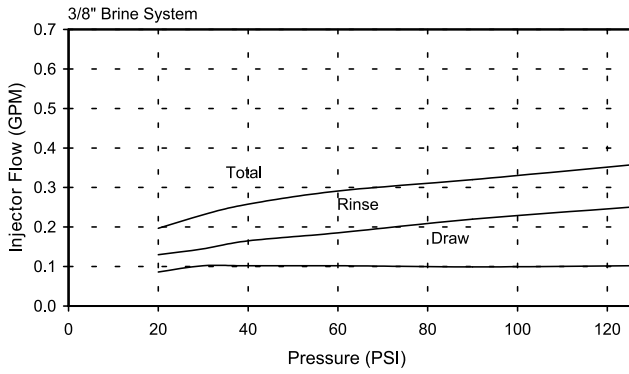

**Injector #00**

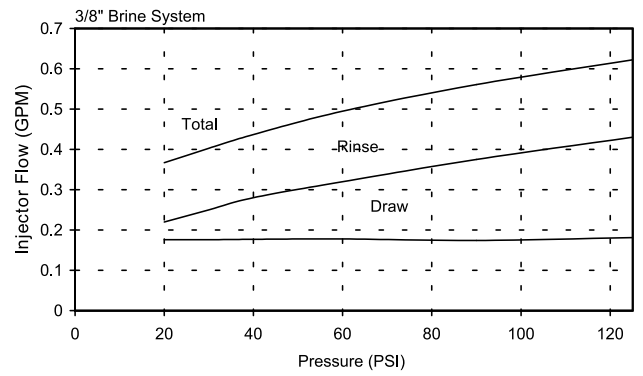

**Injector #0**

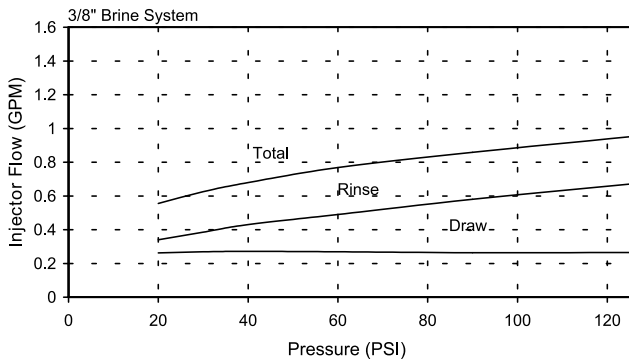

**Injector #1**

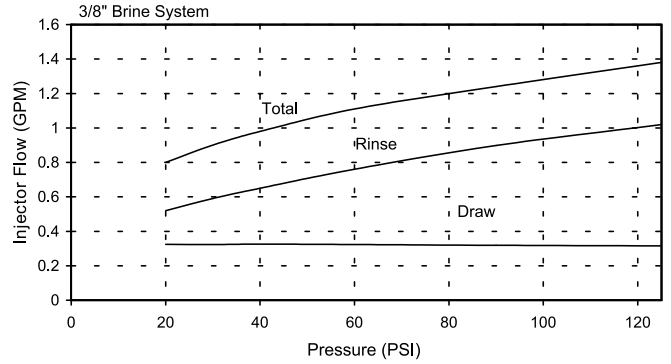

**Injector #2**

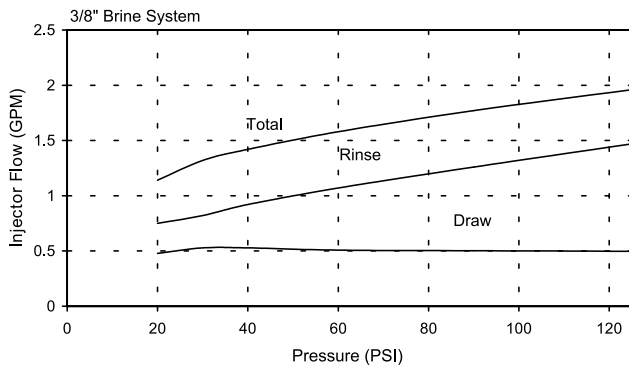

**Injector #3**

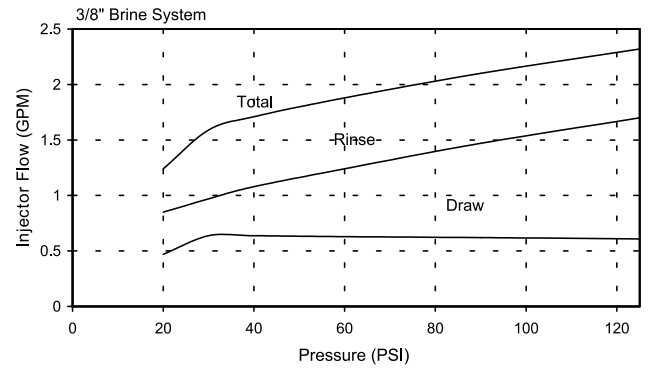

TR18755 Rev B





For Fleck Product Warranties visit:  
Fleck para las garantías de los productos visite: } [waterpurification.pentair.com](http://waterpurification.pentair.com)  
Pour Fleck garanties produit visitez le site :



**WATER QUALITY SYSTEMS**

5730 NORTH GLEN PARK ROAD, MILWAUKEE, WI 53209

P: 262.238.4400 | WATERPURIFICATION.PENTAIR.COM | CUSTOMER CARE: 800.279.9404 | tech-support@pentair.com

All Pentair trademarks and logos are owned by Pentair, Inc. or its affiliates. All other registered and unregistered trademarks and logos are the property of their respective owners. Because we are continuously improving our products and services, Pentair reserves the right to change specifications without prior notice. Pentair is an equal opportunity employer.

43359 REV C AU15 © 2013 Pentair Residential Filtration, LLC All Rights Reserved.