

# OWNER'S INSTRUCTION MANUAL



## Reverse Osmosis Water Purification System

**PROQ-550**

**PROQ-550P**

**PROQ-450**

**PROQ-450P**

**Aquasys** Technologies, Inc.

908-2, Sec.3, ChongDe Rd., Taichung 406, Taiwan

Tel: (886)-4-24222190

Fax: (886)-4-24222327

Email: [sales@puregen.com.tw](mailto:sales@puregen.com.tw)

**PureGen** Technologies, Inc.

5423 "G" Street. Chino CA 91710, USA

Tel: (909)548-0339

Fax: (909)548-0863

[www.puregen.com](http://www.puregen.com)

Email: [sales@puregen.com](mailto:sales@puregen.com)



## Read this before you start system installation

- Do not use with water that is microbiologically unsafe or of unknown quality without adequate disinfection before or after the system. Systems certified for cyst reduction may be used on disinfected water that may contain filterable cysts. Please correct any abnormal water condition such as chlorine, bacteria, pH, temperature, iron, turbidity, hardness, pressures, etc that may effect RO membrane polymers or other component performance in this water system.
  - This reverse osmosis system contains replaceable components critical to the efficiency and proper function of the system. Replacement of these reverse osmosis components should be with ones of identical specification, as defined by the manufacturer to assure the same efficiency and contaminant reduction performance.
  - Min./ Max. working pressure: 40~80 Psi
  - Min./ Max. operating Temp.: 40~80 °F
- Manufacturer warning: This system needs to be flushed 24 hours prior to use.

## INSTALLATION

Your Reverse Osmosis System has been thoroughly tested and inspected for leaks, product water quality, product water output and all operating functions at our factory. The system may have some water in it. Installation must be done by a licensed water professional. Systems installed by non-licensed personnel will void all warranties.

### TAPPING INTO COLD WATER LINE

1. Turn off the cold water supply to the sink faucet.
2. Locate the feed water adapter and ball valve in the installation kit.
3. Use Teflon tape and install the ball valve into the feed water adapter.
4. Disconnect the cold water riser tube and install the slip joint adapter per the instructions below.

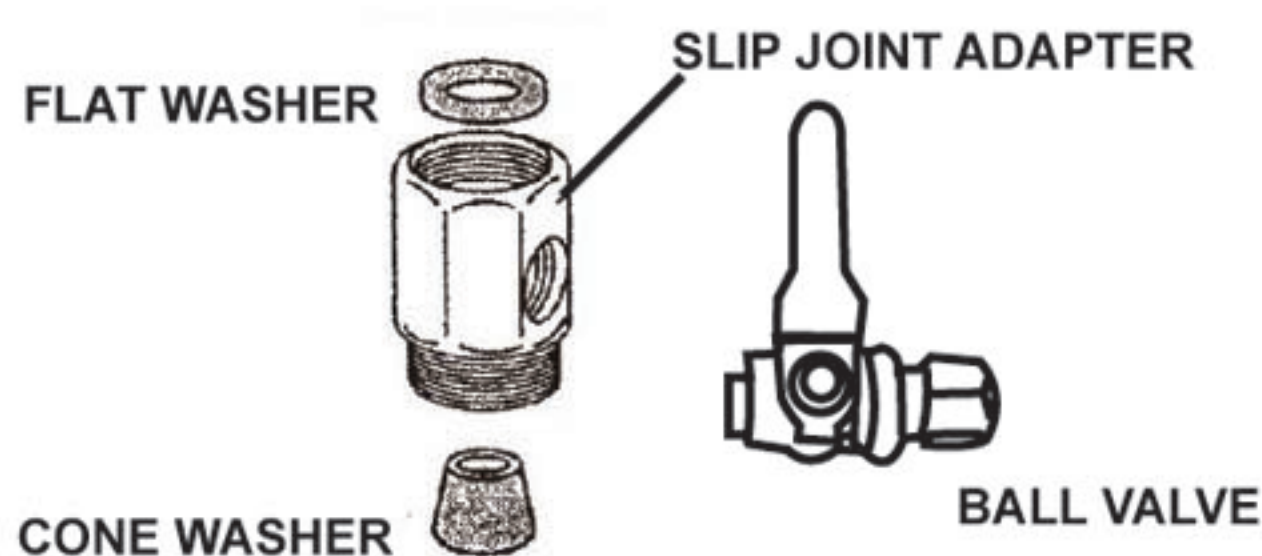

A) **FLEX LINE OR NYLON:** loosen nut and separate cold water riser tube from faucet shank. Gently bend riser tube so that slip joint fits onto faucet shank. If necessary, replace the existing cone washer with a new washer (provided in installation kit) onto the cold water riser tube. Reinstall riser tube onto slip joint adapter and tighten. Check carefully for leaks.

B) **SOLID COPPER RISER TUBE:** Same procedure as flex tubing except you must cut a piece of the riser tube about 3/4" to 1" so the slip joint adapter can fit between faucet and riser tube. Check carefully for leaks.

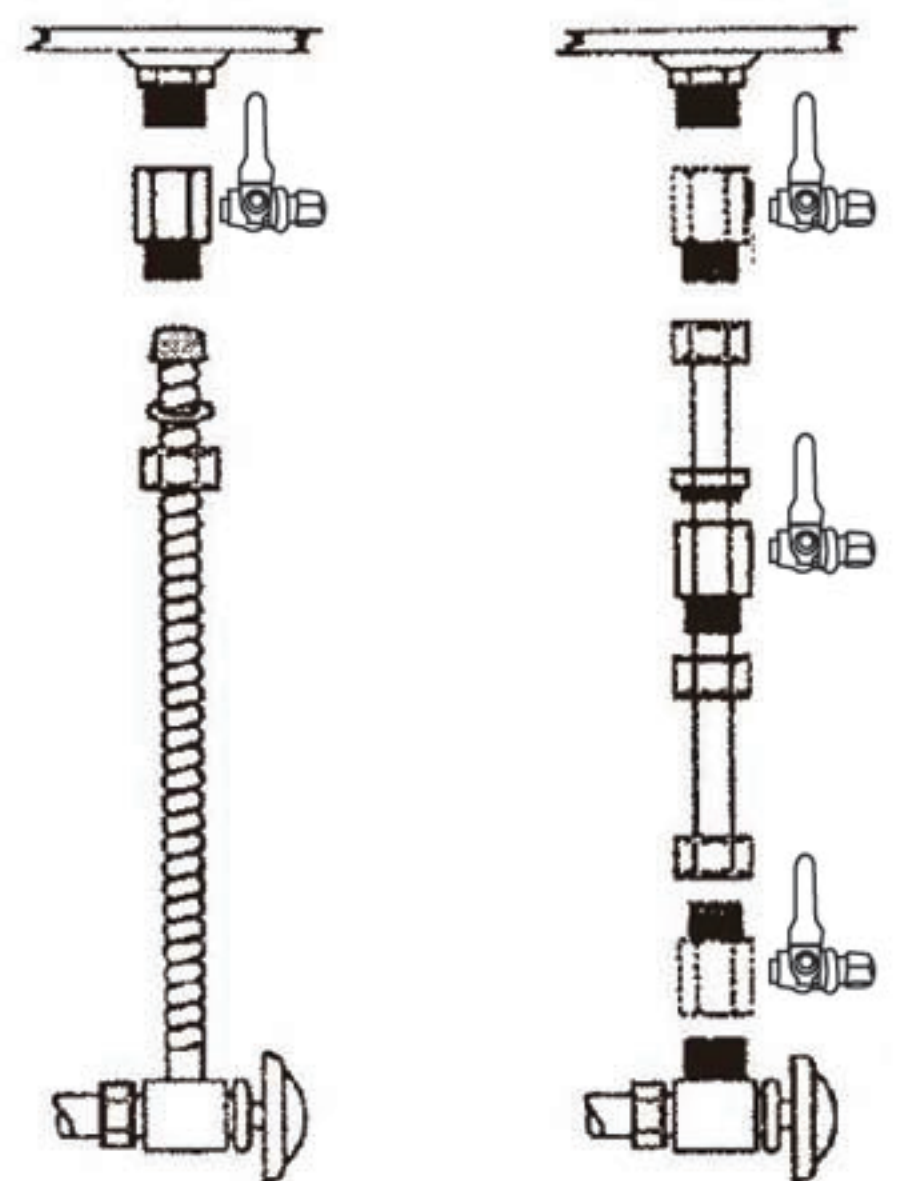

TYPICAL FEED WATER CONNECTIONS

### DRILLING THE HOLE FOR FAUCET

The faucet should be positioned with aesthetics, function and convenience in mind. An ample flat area is required for the faucet base so that it can be drawn down tight. If space is not available on the upper sink area, the faucet can be positioned on the counter top at the edge of the sink. Use caution when drilling. Inspect for any obstruction that may cause difficulty when installing the faucet. The sink drilling process, while not complicated, requires a certain amount of caution and forethought. Porcelain sinks can easily chip if care is not exercised when drilling the hole for the faucet assembly.

### PORCELAIN ENAMEL SINK

A 1/2" hole is required. To drill the hole, begin with a 1/4" carbide tipped drill bit as a pilot hole. Follow with a 1/2" carbide tipped drill. When drilling starts keep a firm and steady downward pressure. Slowly drill through the porcelain portion of the sink to minimize chipping.

Tip: Use a rubber piece over the drill bit to prevent hitting the porcelain with the drill chuck when the drill hole is completed.



## STAINLESS STEEL SINK

Use an appropriate bit designed for stainless steel. Be sure your drill bit is sharp to prevent overheating the stainless. Overheating the stainless steel will make drilling the hole extremely difficult. Debur the hole before continuing.

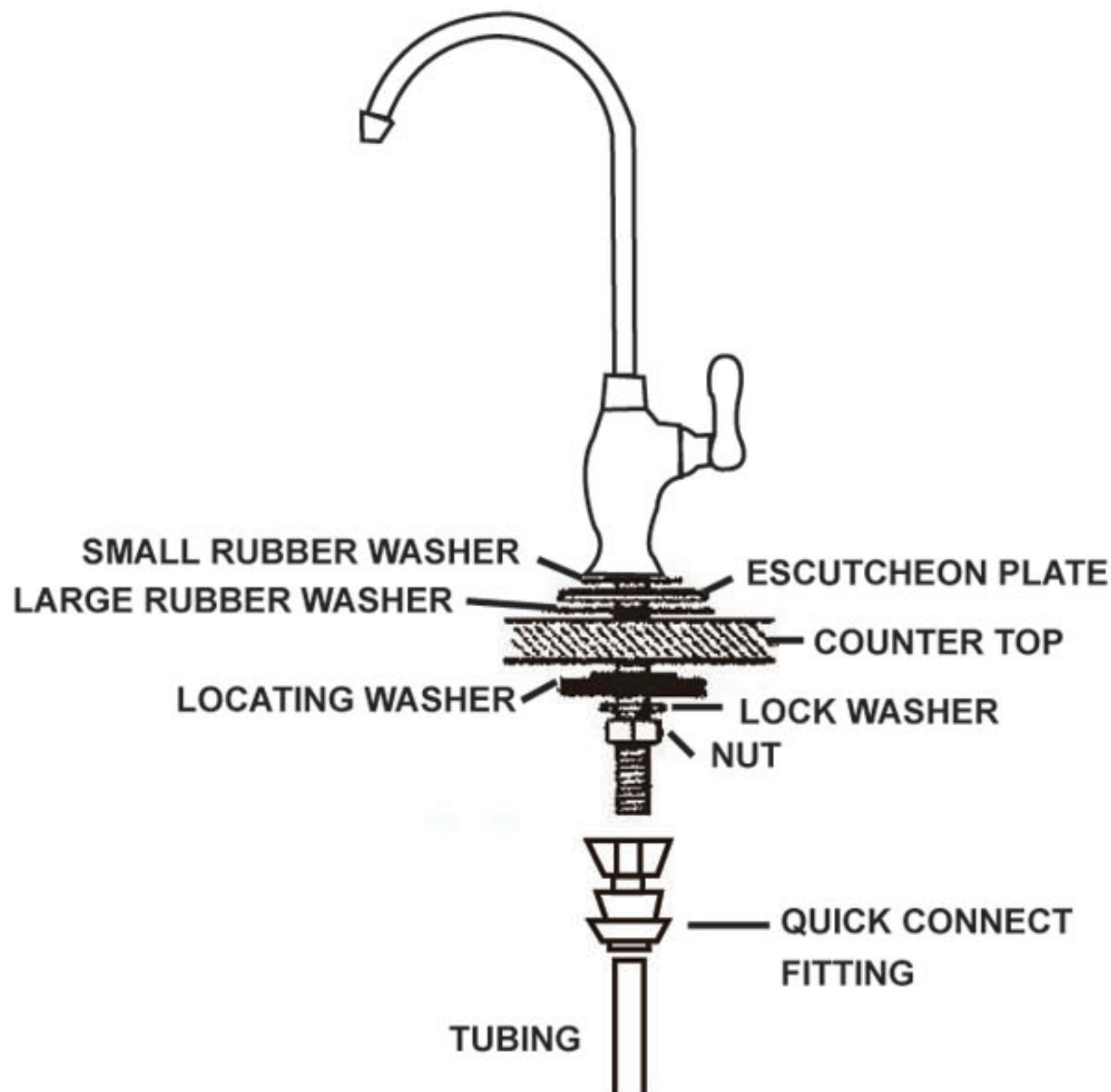

## MOUNTING THE DRAIN CLAMP

The drain clamp will fit most standard drain size of 1 1/4". Install the drain clamp above the P-trap and drill a 1/4" - 3/8" hole where the drain tube is to be connected. Tighten bolts and nuts evenly. Brackets should be parallel.

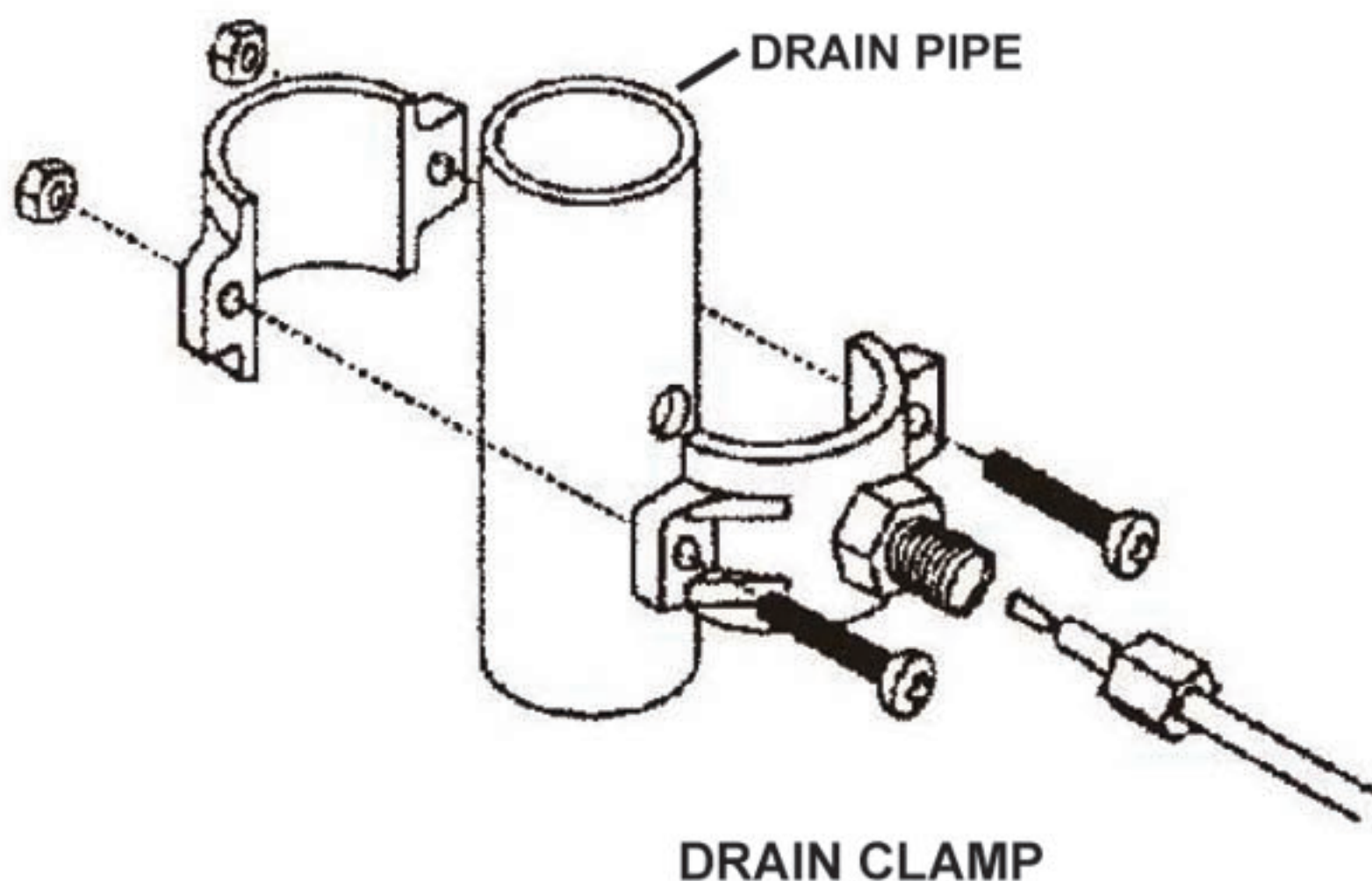

## MOUNTING TEH BALL VALVE

Make sure the ball valve is tight but not overtight. Use Teflon tape to prevent leaks.

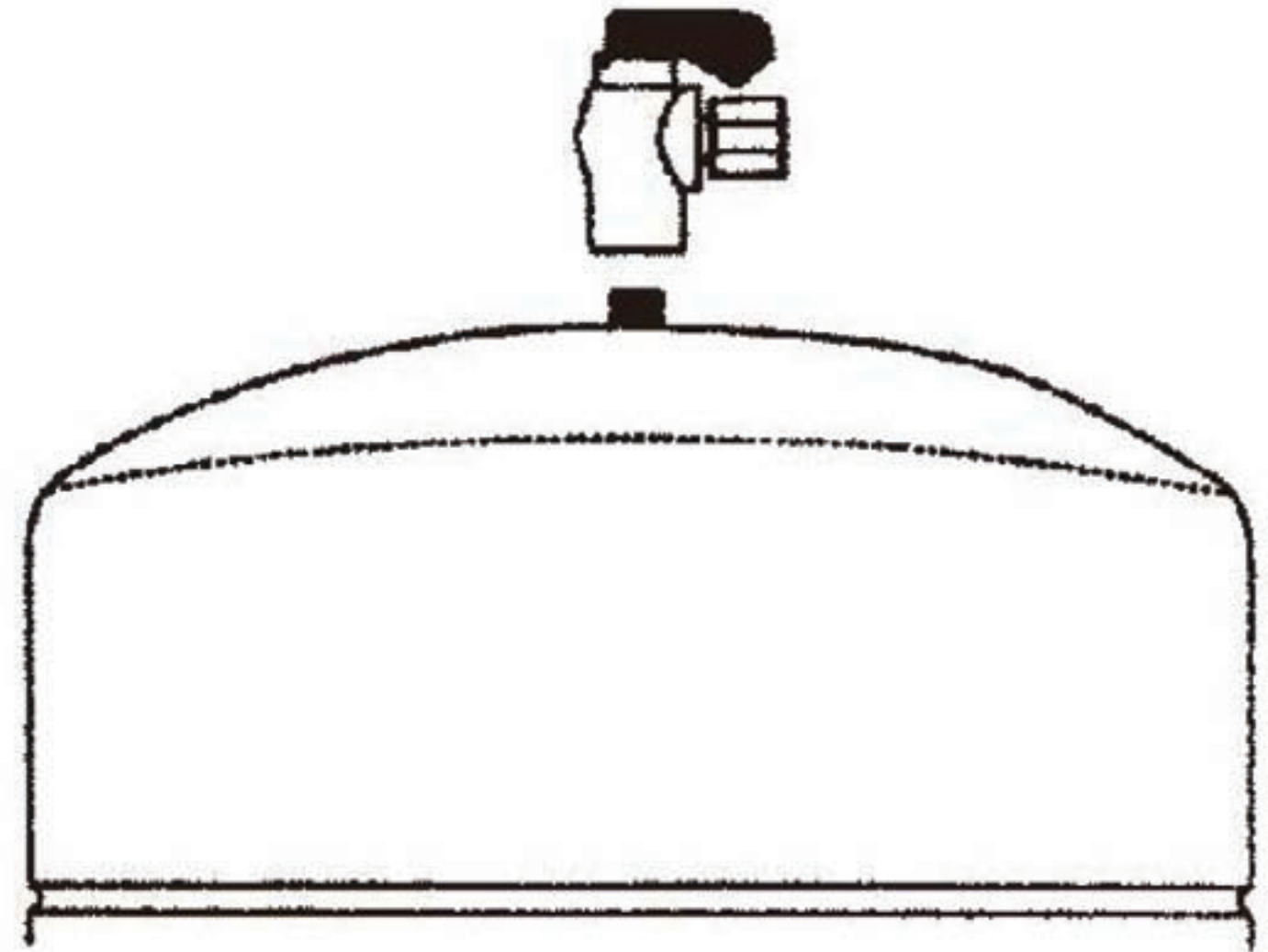

## MOUNTING The R.O. SYSTEM

( see installation diagram )

Makes sure there is sufficient space under the counter for installation. When space is not available for the storage tank, it may be placed in an adjoining cabinet.

Mounting holes are on the back of the RO system so it can be mounted on either side of the cabinet wall. The Ro system should be mounted at least 3" from the cabinet floor and secured by using the provided screws.

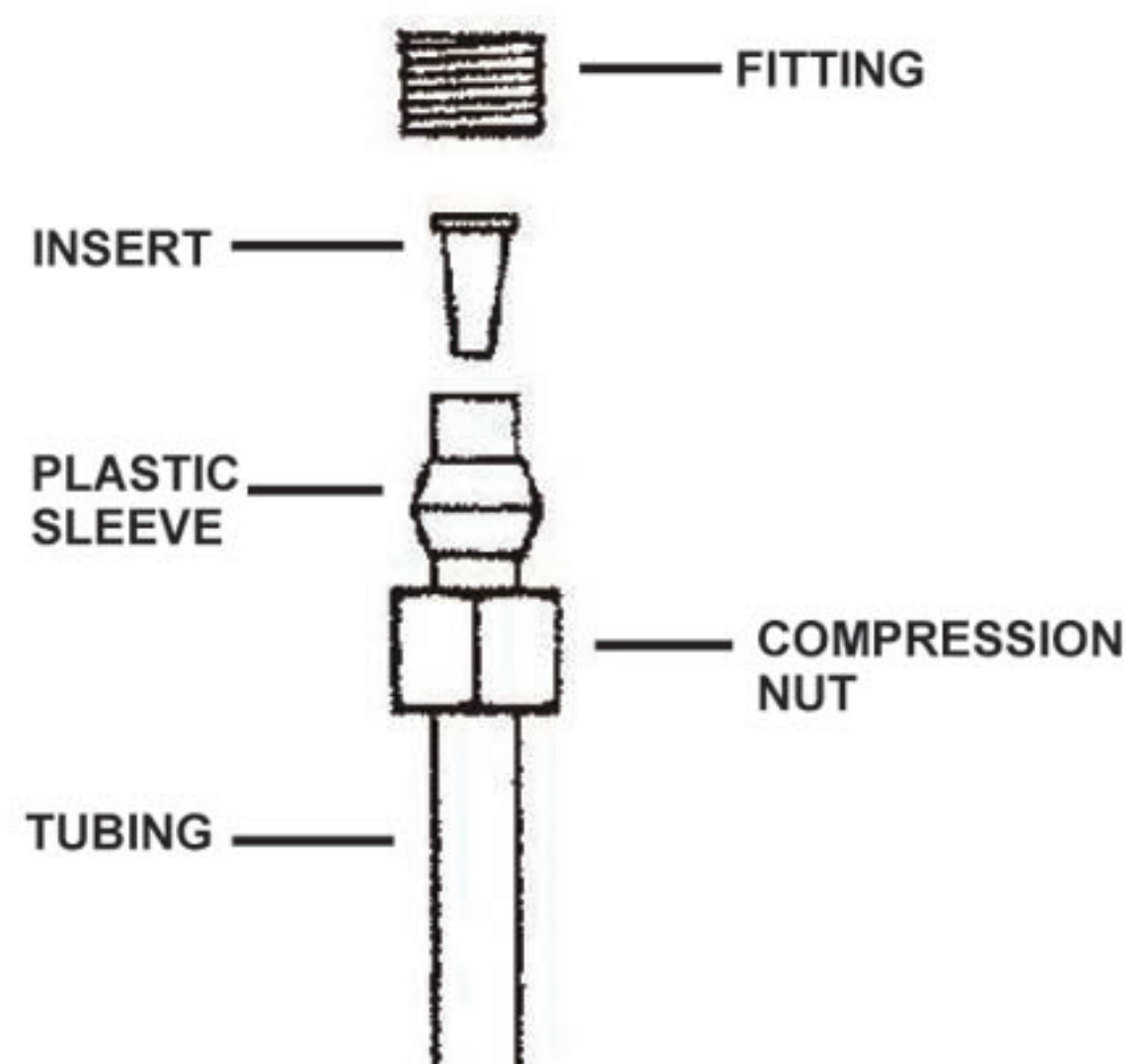

**ORANGE TUBE:** connect from system to feed water adapter.

**BLUE TUBE:** connect from system to the threaded faucet shank.



**YELLOW TUBE:** connect from the system to the ball valve on the storage tanks.

**BLACK TUBE:** Connect from the membrane drain to the drain clamp.

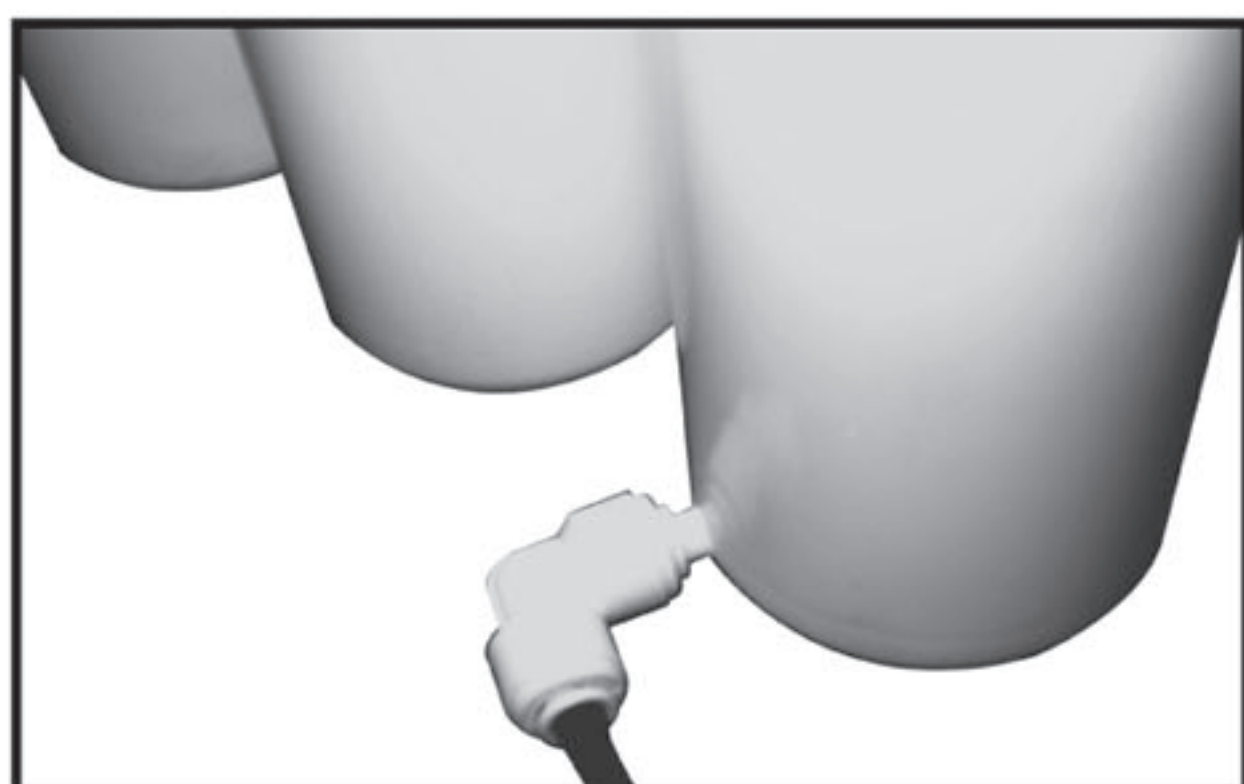

## REFRIGERATOR ICE MAKER OR WATER COOLER HOOK UP

The RO system can also supply water to a refrigerator's ice maker and water dispenser or water cooler up to 15 feet away.

1. Cut the blue tubing near the faucet and install a "T" fitting.
2. Run 1/4" tubing from the "T" fitting to the refrigerator or water cooler.

**Tip:** Longer distances may be possible but the tubing size between the R.O. system and the appliance must be increased depending on length.

**NOTE:** When the system is connected to a refrigerator or water cooler, it may require longer than 2~3 hours for the system to become fully charged for use.

## SYSTEM START UP

1. Make sure all connections are secure.
2. Slowly open the ball valve on the feed water adapter allowing water to enter the system.
3. (models with pump only) plug in the transformer to the wall outlet.
4. Turn ball valve on the storage tank to the "OPEN" position.
5. Allow system to run while cleaning up tools. It will take several minutes for the system to produce water and several hours to fill the storage tank.
6. Check all connections, including those inside the system for leaks and tighten or repair fittings as necessary.

## NOTE:

- A) We supply installation components that will work for most applications. It is the customer's responsibility to supply installation components if the supplied kit does not meet your needs or is not allowed by state or local codes.
- B) Please check with state and local laws and regulations.
- C) Air bubbles and noise may be present for several days after installation.
- D) Drain the first two full tanks of fresh water produced by the R.O. system.

## OPERATING THE RO SYSTEM

- The RO system will perform better and last longer with heavier usage. We encourage you use RO water to cook, make coffee, tea, mixed drinks, etc.
- The system is designed for easy use and works automatically. It will start and stop automatically keeping the storage tank at optimal levels.
- We recommend draining the storage tank weekly by opening the faucet and allowing the water to run until it slows to a trickle. This will keep the water fresh and increase system performance.

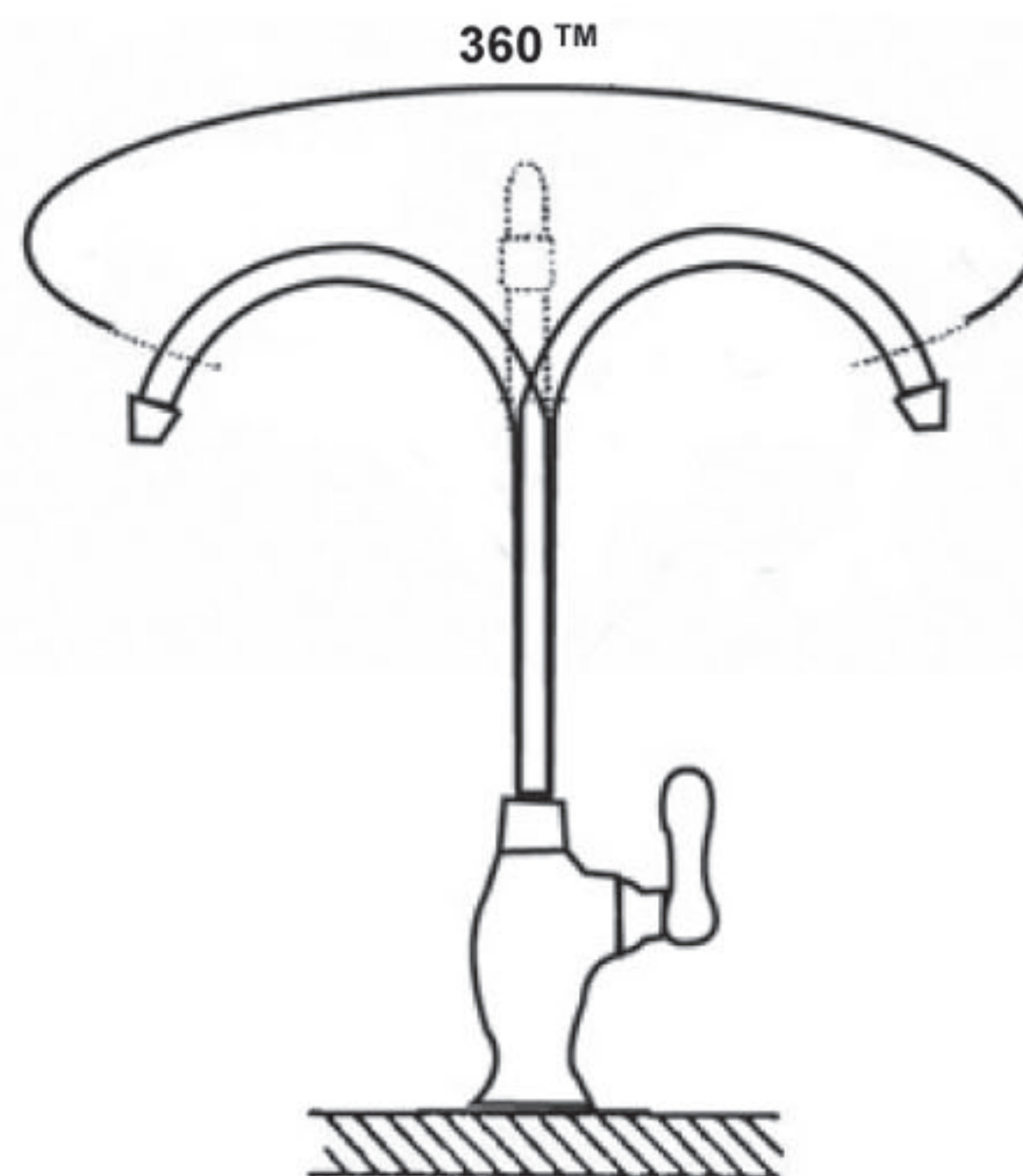

- Faucet spigot can swiveled out of the way without damage.

**NOTE:** In case of emergency such as a water leak, filter housing break, etc. Turn off the feed water valve and the storage tank valve and repair the system as needed.



## MAINTENANCE AND SERVICING

The RO system is designed for easy maintenance. It is important that the filters be changed on a routine schedule. Failure to do so may reduce the life of the membrane and could void your warranty.

### APPROXIMATE FILTERS AND MEMBRANE LIFE

- **STAGE ONE:** sediment 3-12 months
- **STAGE TWO:** Pre carbon 6-12 months
- **STAGE THREE:** carbon 6-12 months
- **STAGE FOUR:** membrane 1-3 years
- **STAGE FIVE:** post carbon 6-12 months
- **BOOSTER PUMP**  
(models with pump only)
- Replace pump diaphragm every 2-3 years.

Membrane life can vary significantly depending on the condition of the water supplied to the system. It is strongly recommended to have your R.O. system tested periodically to verify that it maintains the performance levels claimed by the manufacturer.

### CHANGING SEDIMENT FILTER , PRE- CARBON, POST-CARBON

1. (Model with pump only) Unplug the transformer.
2. Shut off the feed water supply to the system.
3. Empty the storage tank by opening the R.O faucet.
4. Remove the filters by turning them counter-clockwise by hand.
5. Remove and properly dispose of the used filter cartridges. Install the new filter cartridges.
6. Tighten filter securely to avoid any leaks
7. Open the feed water supply to the system.
8. Drain the first two tanks of product water after each replacement of the filters.



### MEMBRANE

Remove the drain line quick connect fitting from the bottom of the membrane housing. Replace with a new membrane and re-install the quick connect fitting. Always inspect and replace the capillary flow restrictor if necessary.

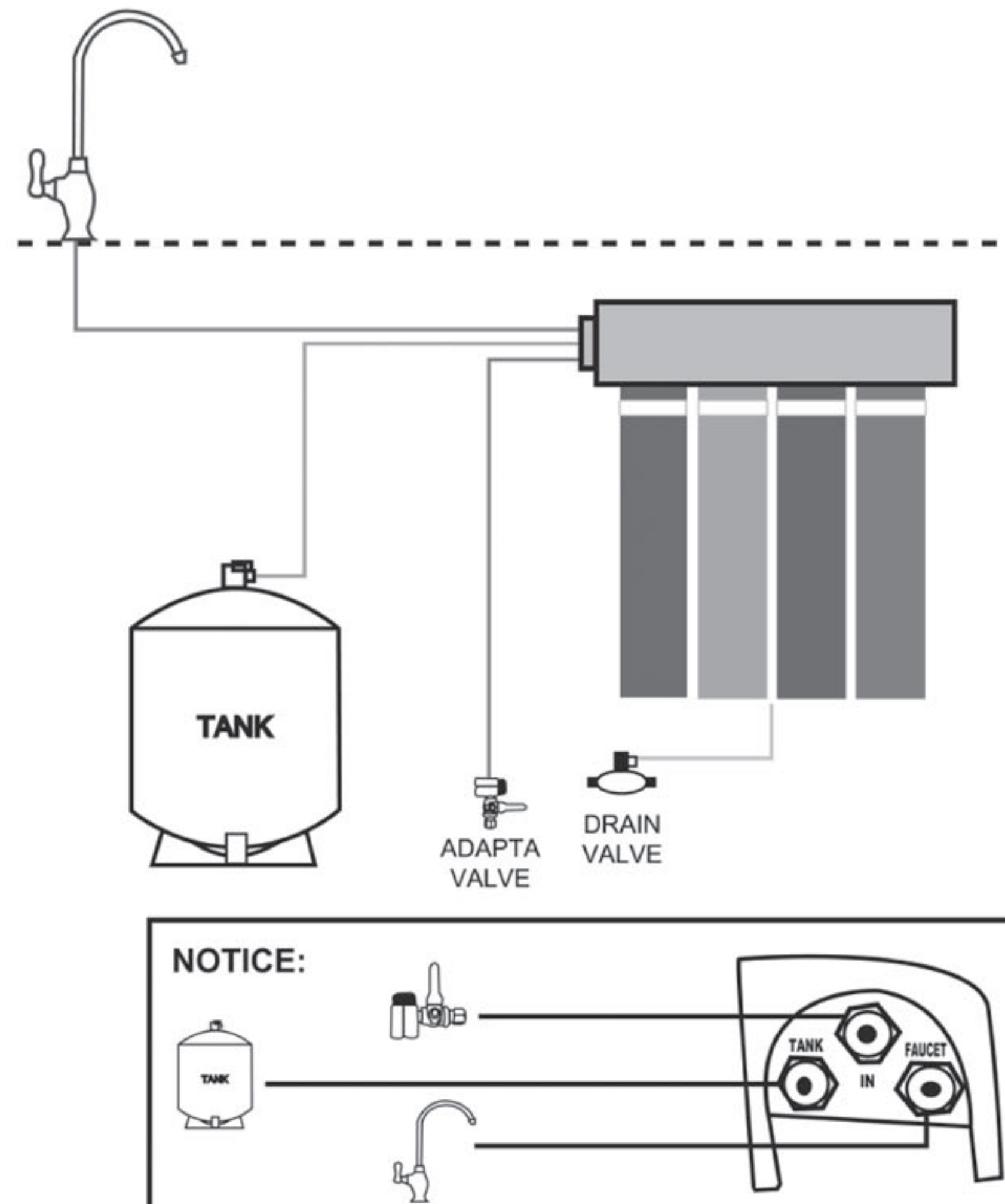



## STAGE 5 POST CARBON (IF APPLICABLE)

Push in collars on inline filter and remove old filter. Check tubing for damage, scratches, or wear. Replace if necessary. Purge with water for 10-20 minutes prior to use.

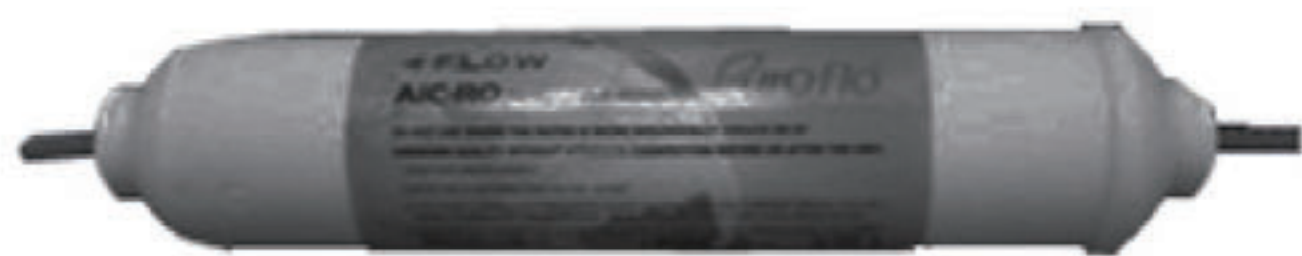

INLINE CARBON

## TROUBLE SHOOTING

### LEAKS

1. Filter housing: the O-Ring in the filter may be dirty or stretched. The O-ring may not be in the groove. Repair or replace as needed.
2. Fitting connection: check to see that the fitting is tight and not cracked, repair or replace as needed.
3. Tubing: Inspect for wear, scratches, or damage. Replace if needed.

### FAUCET

The 1/4 turn ceramic seat faucet should provide many years of trouble free service. Replace the faucet if it starts to leak.

### BOOSTER PUMP (MODELS WITH PUMP ONLY)

If the product water decreases and the membrane is in good condition, the diaphragm in the booster pump may need replacement. Inspect the pressure switch for proper operation, transformer, and motor, repair or replace as needed.

### NO WATER OR SLOW FLOW

1. It will takes approximately 3-5 hours from start up to fill the storage tank and longer if connected to a refrigerator dispenser and / or ice maker.
2. Check the feed water supply valve to see that it is in the "OPEN" position.

3. The storage tank holds approximately 1.5~3.0 gallons of water. In heavy use this supply can be depleted, but the system will automatically fill the tank again, In the event that depletion becomes a recurring event, an additional or larger storage tank may be installed.
4. Check all tubing to verify proper connections. Make sure that there are no restrictions or kinks in the tubing connections.
5. Make sure that the storage tank valve is in the "OPEN" position.
6. Check the pre filter for clogging. A dirty filter cartridge will restrict flow to the system. Change more frequently if needed.
7. Low feed water pressure can cause low storage tank pressure and or slow flow from the faucet. If low feed water pressure becomes a problem, a pressure booster pump may be installed.
8. If the storage tank is heavy with water but there is no water flow from the faucet, it has lost its air charge and needs to be serviced or replaced. The air charge in the tank should be about 5-7 PSI when the tank is empty.

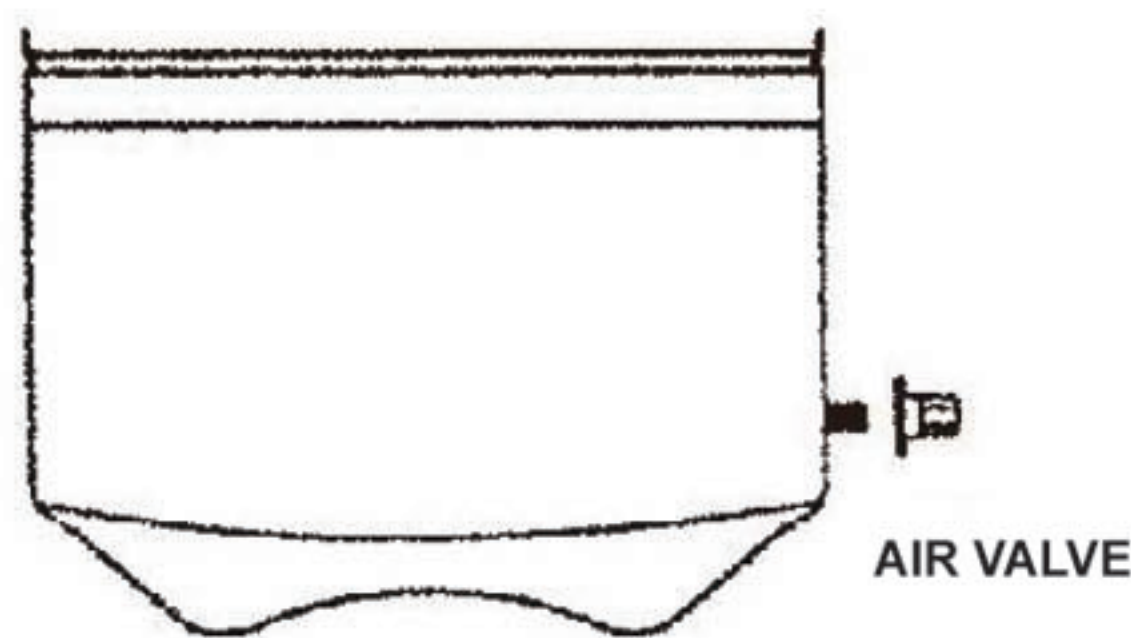

9. Cold feed water will reduce the production capacity of the membrane substantially in proportion to the actual water temperature.



# INSTALLATION DIAGRAM REVERSE OSMOSIS WATER PURIFICATION SYSTEM

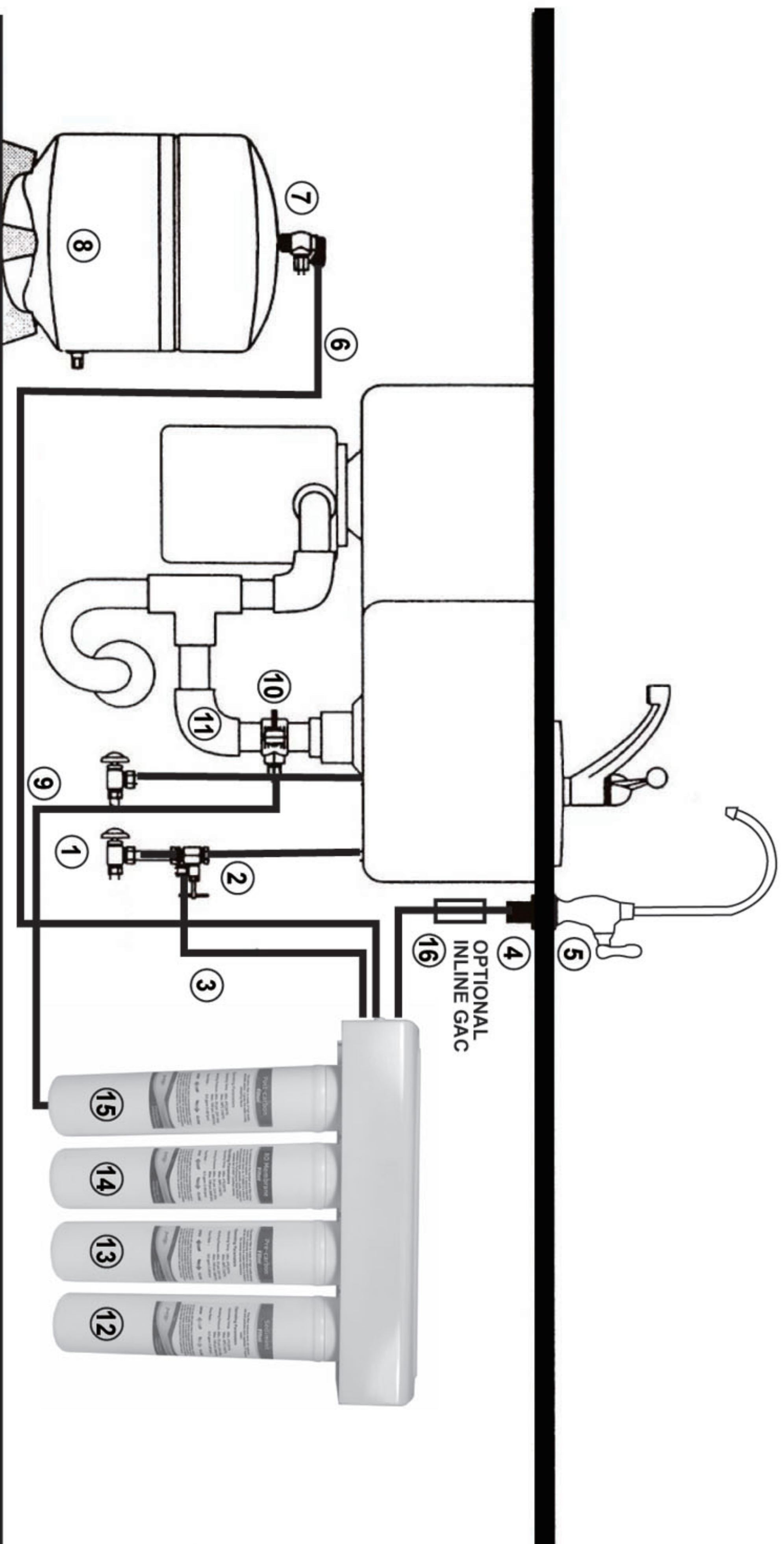

- 1. Cold water shut off valve
- 2. Feed water adapter
- 3. Orange tubing: to feed water
- 4. Blue tubing: to faucet
- 5. Faucet
- 6. Yellow tubing: to storage tank

- 7. Tank ball valve
- 8. Storage tank
- 9. Black tubing: to drain
- 10. Drain saddle
- 11. Drain line
- 12. Sediment filter 5 microns

- 13. Pre carbon filter
- 14. Post-carbon filter
- 15. Membrane
- 16. Optional Inline Filter

NOTICE:

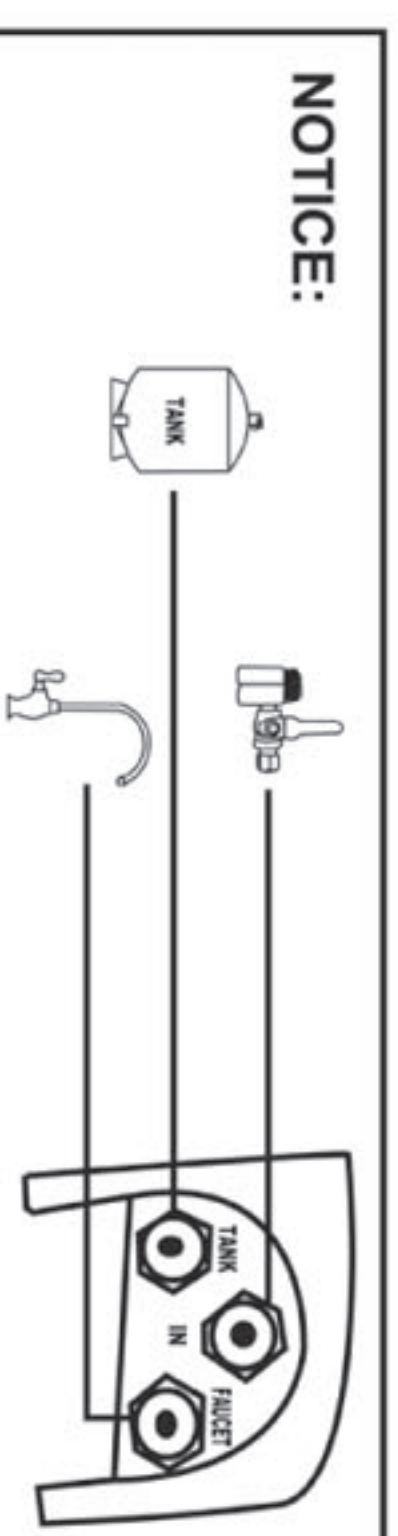



# LIMITED WARRANTY

## I. WHAT YOUR WARRANTY COVERS

Your PureGen Reverse Osmosis System is warranted to the original owner to be free of defects in material and workmanship from the date of purchase for one year. PureGen will, within 1 year of purchase, replace the entire unit (excluding the replaceable filters) at no charge. The replaceable filters are warranted for defects in material and workmanship only. Service life of replaceable filters varies with local water and is thus not warranted.

## II. CONDITIONS OF WARRANTY

System must be maintained and serviced with PureGen Reverse Osmosis system approved replacement parts and filters, PureGen company's liability is limited to the cost of repair or replacement (at our option) of any defective part; it does not include incidental or consequential damages of any kind. System must be installed by a licensed water treatment professional.

## III. WHAT DOES NOT WARRANT

Warranty is void if product failure or damage results from freezing, neglect, misapplication, fouling with sediment, or failure to operate the system in accordance with the manufacturer's recommended procedures and guidelines:

- The Reverse Osmosis System must be hooked up to a potable municipal cold water supply
- The hardness of the water cannot exceed 7 grains per gallon or 120 ppm
- **The water pressure must be between 35 and 70 PSI**
- Incoming water to the RO cannot exceed 90°F
- **Incoming TDS/Total Dissolved Solids not to exceed 800 ppm**

## IV. OBTAINING WARRANTY SERVICE

For warranty service, simply contact PureGen or your authorized dealers. Be sure to show proof of date of original purchase.

## V. LIMITATIONS AND EXCLUSIONS

PUREGEN WILL NOT BE RESPONSIBLE FOR ANY IMPLIED WARRANTIES. PUREGEN WILL NOT BE RESPONSIBLE FOR ANY INCIDENTAL OR CONSEQUENTIAL DAMAGES, INCLUDING TRAVEL EXPENSE, TELEPHONE CHARGES, LOSS OF REVENUE, LOSS OF TIME, INCONVENIENCE, LOSS OF USE OF THE EQUIPMENT AND ITS FAILURE TO FUNCTION PROPERLY.