

MODEL 5600SE

Upflow Brining

Service Manual



IMPORTANT: Fill in pertinent information on page 2 for future reference.

MODEL 5600SE Upflow

General Residential Installation Check List

WATER PRESSURE: A minimum of 25 pounds of water pressure is required for regeneration valve to operate effectively.

ELECTRICAL FACILITIES: An uninterrupted alternating current (A/C) supply is required. Please make sure your voltage supply is compatible with your unit before installation.

EXISTING PLUMBING: Condition of existing plumbing should be free from lime and iron buildup. Piping that is built up heavily with lime and/or iron should be replaced. If piping is clogged with iron, a separate iron filter unit should be installed ahead of the water softener.

LOCATION OF SOFTENER AND DRAIN: The softener should be located close to a clean working drain and connected according to local plumbing codes.

BY-PASS VALVES: Always provide for the installation of a by-pass valve if unit is not equipped with one.

CAUTION: Water pressure is not to exceed 120 p.s.i., water temperature is not to exceed 110°F, and the unit cannot be subjected to freezing conditions.

Valve Installation and Start-up Procedures

1. Place the softener tank where you want to install the unit, making sure the tank is level and on a firm base.
2. During cold weather it is recommended that the installer warm the valve up to room temperature before operating.
3. All plumbing should be done in accordance with local plumbing codes. The pipe size for the drain should be a minimum of 1/2". Backwash flow rates in excess of 7 gpm or length in excess of 20' require 3/4" drain line.
4. The 1" distributor tube (1.050 O.D.) should be cut 2.0" below the top of each tank. Note: Only use silicone lubricant.
5. Lubricate the distributor o-ring seal and tank O-ring seal. Place the main control valve on tank.
6. Solder joints near the drain must be done prior to connecting the Drain Line Flow Control fitting (DLFC). Leave at least 6" between the DLFC and solder joints when soldering pipes that are connected on the DLFC. Failure to do this could cause interior damage to DLFC.
7. Teflon tape is the only sealant to be used on the drain fitting.
8. Make sure that the floor is clean beneath the salt storage tank and that it is level.
9. Place approximately 1" of water above the grid plate. If a grid is not utilized, fill to the top of the air check in the salt tank. Do not add salt to the brine tank at this time.
10. On units with a by-pass, place in by-pass position. Turn on the main water supply. Open a cold soft water tap nearby and let run a few minutes or until the system is free from foreign material (usually solder) that may have resulted from the installation. Once clean, close the water tap.
11. Place the by-pass in service position and let water flow into the mineral tank. When water flow stops, slowly open a cold water tap nearby and let run until the air is purged from the unit. Then close tap.
12. Plug the valve into an approved power source. Once the valve is powered it will drive to the Service Position.

MODEL 5600SE Upflow

Control Start-up Procedures

Whenever the valve is in *Service* the current time of day can be set, the control programmed, or an extra regeneration initiated at any time.

1. Set Time Of Day

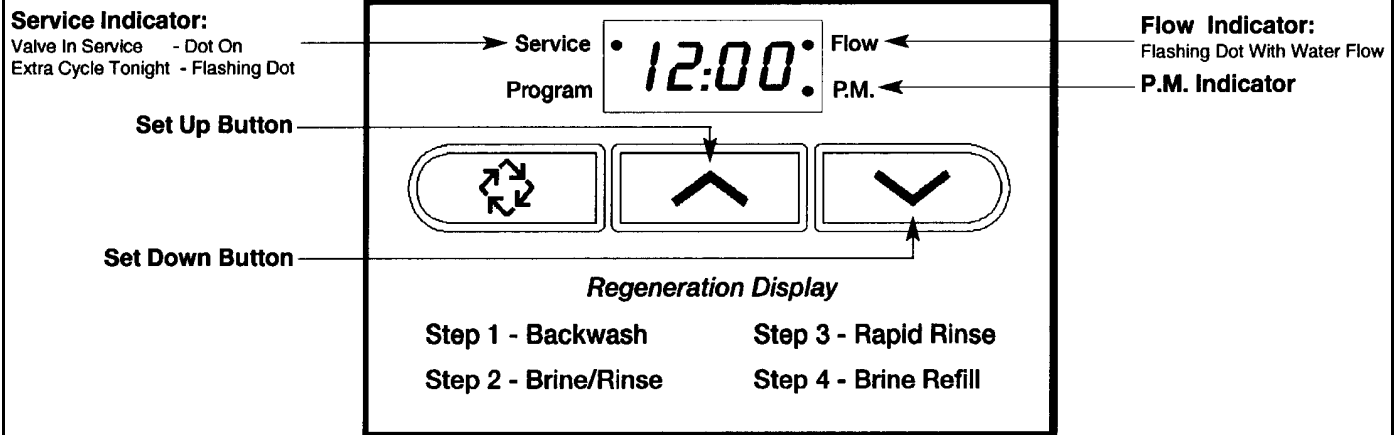

Push either the Up or Down Set Button once to adjust Time Of Day Display by one digit.
Push and hold either Up or Down Set Button to adjust Time Of Day Display by several digits.

2. Enter Control Programming Mode

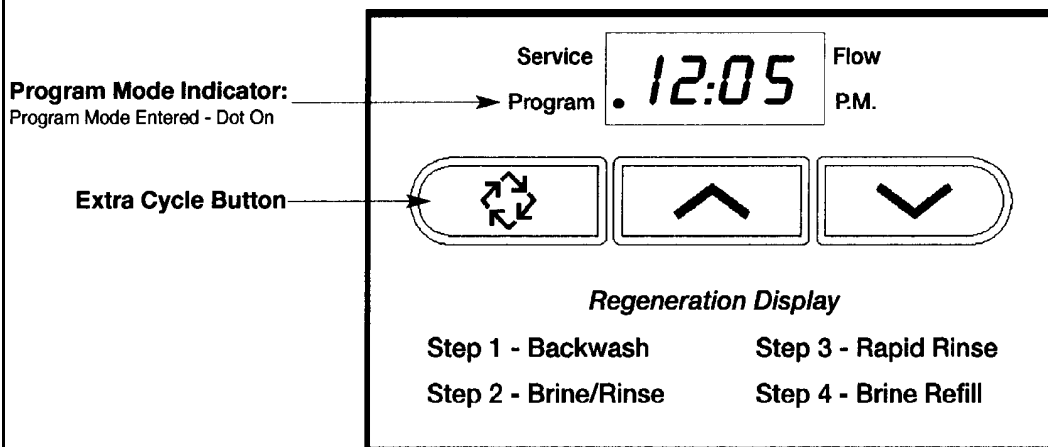

1. Push and hold for 5 seconds *both* the Up and down Set Buttons to enter Programming Mode.
2. Push the *Extra Cycle Button* once per display until all have been viewed and this mode is exited and normal operation is resumed.

MODEL 5600SE Upflow

Control Start-up Procedures (Cont'd.)

Depending on current control programming, option setting displays that are not required to be set will not be viewed.

3. Set Control Programming

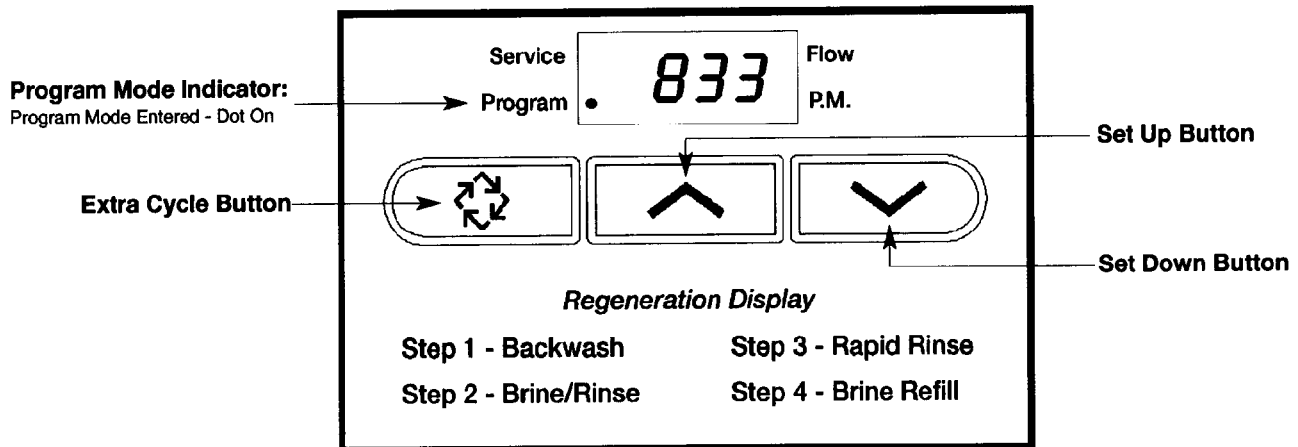

1. The first option setting display that appears in the Program Mode is Treated Water Capacity. Using the Set Up or Down Buttons, set the amount of treated water that can flow through the unit before a regeneration is required. For Example:

650 Gallons Capacity Service Flow
Program • 650 P.M.

2. Push the Extra Cycle Button. The second option setting display that appears is Regeneration time. Using the Set Up or Down Buttons, set the desired time of day when a regeneration can occur, if required. For Example:

2:00 A.M. Regeneration Time Service Flow
Program • 2:00 P.M.

3. Push the Extra Cycle Button. The third option setting display that appears is Regeneration Day Override. Using the Set Up or Down Buttons, set the maximum number of days before a regeneration cycle must occur. For Example:

Regenerate Every
7 Days Minimum Service Flow
Program • A - - 7 P.M.

4. Control programming is now complete. Push the Extra Cycle Button. This will exit the control from the Programming Mode, and resume Normal Operation.

MODEL 5600SE Upflow

Control Start-up Procedures (Cont'd.)

4. Start An Immediate Extra Cycle

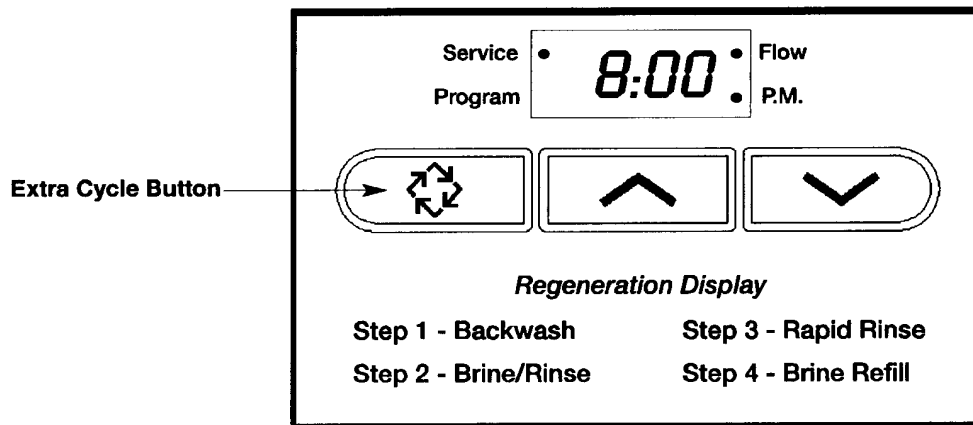

When starting an Extra Cycle, you will have one or two options:

1. **Press and Release the Extra Cycle Button:**
 - With *Immediate Regeneration* controls the control will go into regeneration cycle immediately.
 - With *Delayed Regeneration* controls the Service Arrow will begin to flash immediately and a regeneration will occur at the present regeneration time (i.e. 2:00 a.m.)
2. **Press and Hold for 5 seconds the Extra Cycle Button:**
 - With *Delayed Regeneration* controls this will force the control to go into regeneration cycle immediately.

5. Regeneration Cycle Displays

The following series of displays appear when the control enters a regeneration cycle:

Valve Driving To Regen. Step #1	Service Program	1 - - -	Flow P.M.	<i>Then</i>	Service Program	1 - - 8	Flow P.M.	Less Than 9 Min. Remain In Regen. Step #1
Valve Driving To Regen. Step #2	Service Program	2 - - -	Flow P.M.	<i>Then</i>	Service Program	2 - 58	Flow P.M.	Less Than 59 Min. Remain In Regen. Step #2
Valve Driving To Regen. Step #3	Service Program	3 - - -	Flow P.M.	<i>Then</i>	Service Program	3 - - 8	Flow P.M.	Less Than 9 Min. Remain In Regen. Step #3
Valve Driving To Regen. Step #4	Service Program	4 - - -	Flow P.M.	<i>Then</i>	Service Program	4 - 11	Flow P.M.	Less Than 12 Min. Remain In Regen. Step #4
Regen Complete. Valve Driving To Service	Service Program	- - - -	Flow P.M.	<i>Then</i>	Service Program	8:00	Flow P.M.	Valve Has Returned To Service

MODEL 5600SE Upflow

Control Start-up Procedures (Cont'd.)

6. Fast Cycle Valve Thru Regeneration

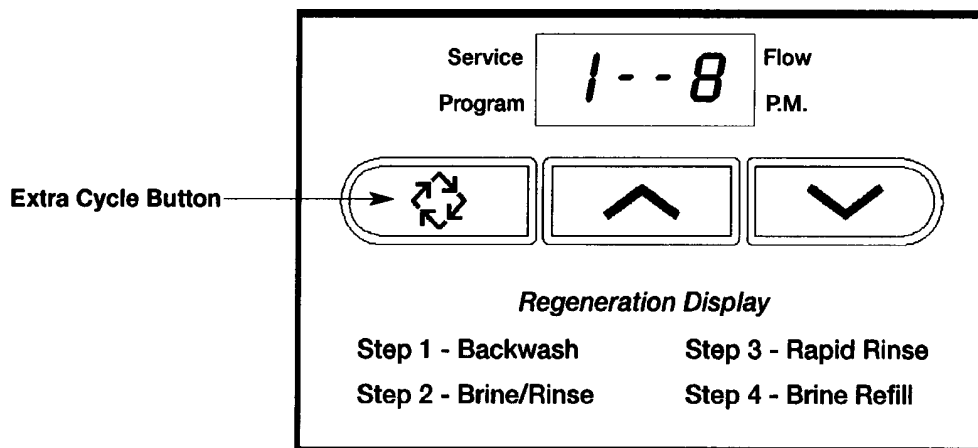

- A. Once the valve reaches Regen Step #1 let water run to drain for about 5 minutes. Next, manually step the valve through a regeneration cycle checking valve operation in each step:
- B. Push the Extra Cycle Button once to advance the valve to Regen Step #2.
- C. Push the Extra Cycle Button once to advance the valve to Regen Step #3. (Optional)
- D. Push the Extra Cycle Button once to advance the valve to Regen Step #4. (Optional)

7. Final Set-Up

With proper valve operation verified:

- A. Add water to the top of the air check. Manually step the valve to the Brine Draw Position and allow the valve to draw water from the brine tank until it stops. Note: The air check will check at approximately the midpoint of the screened intake area.
- B. Next, manually step the valve to the Brine Refill Position and allow the valve to return to Service automatically.
- C. With the valve in Service, check that there is about 1.0" of water above the grid in the brine tank, if used.
- D. Fill the brine tank with salt.
- E. Set-Up is now finished, the control can now be left to run automatically.

MODEL 5600SE Upflow

Control Operation

Timeclock Regeneration Valves

In normal operation the Time Of Day Display will be viewed at all times. The control will operate normally until the number of days since the last regeneration reaches the Regeneration Day Override setting. Once this occurs, a regeneration cycle will then be initiated at the preset Regeneration Time.

Flow Meter Equipped Valves

In normal operation the Time Of Day Display will alternate being viewed with a Volume Remaining Display. This display will be in gallons. As treated water is used, the Volume Remaining Display will count down from a maximum value to zero or (----). Once this occurs a regeneration cycle will then be initiated immediately or delayed to the set Regeneration Time. Water flow through the valve is indicated by the Flow Dot that will flash in a direct relationship to flow rate. For Example:

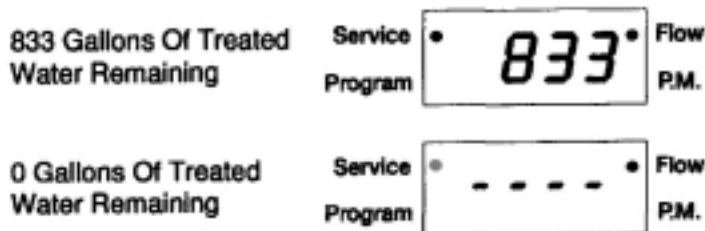

Immediate Regeneration Valves With Days Between Regeneration Override Set

When the valve reaches its set Days Since Regeneration Override value a regeneration cycle will be initiated immediately. This event occurs regardless of the Volume Remaining display having reached zero gallons.

Delayed Regeneration Valves With Days Between Regeneration Override Set

When the valve reaches its set Days Since Regeneration Override value a regeneration cycle will be initiated at the preset Regeneration Time. This event occurs regardless of the Volume Remaining display having reached zero gallons.

Control Operation During Regeneration

In Regeneration the control will display a special *Regeneration Display*. In this display the control will show the current regeneration step number the valve is advancing to, or has reached, and the time remaining in that step. The step number displayed will flash until the valve has completed driving to this regeneration step position. Once all regeneration steps have been completed the valve will return to Service and resume normal operation. For Example:

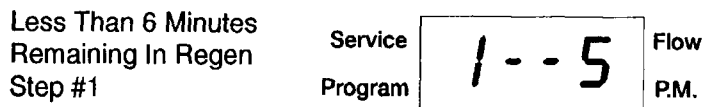

Pushing the Extra Cycle Button during a regeneration cycle will immediately advance the valve to the next cycle step position and resume normal step timing.

Control Operation During Programming

The control will only enter the Program Mode with the valve in Service. While in the Program Mode the control will continue to operate normally monitoring water usage and keeping all displays up to date. Control programming is stored in memory permanently. There is no need for battery backup power.

Control Operation During A Power Failure

During a power failure all control displays and programming will be stored for use upon power re-application. *The control will retain these values for years, if necessary, without loss.* The control will be fully inoperative and any calls for regeneration will be delayed. The control will upon power re-application resume normal operation from the point were it was interrupted. *An indication that a power outage has occurred will be an inaccurate time of day display.*

MODEL 5600SE Upflow

Water Conditioner Flow Diagrams (Upflow Brining)

Using Yellow Cycle Cam (Part No. 24598) (Cont'd.)

Brine/Slow Rinse Position (Regeneration Cycle Step 1)

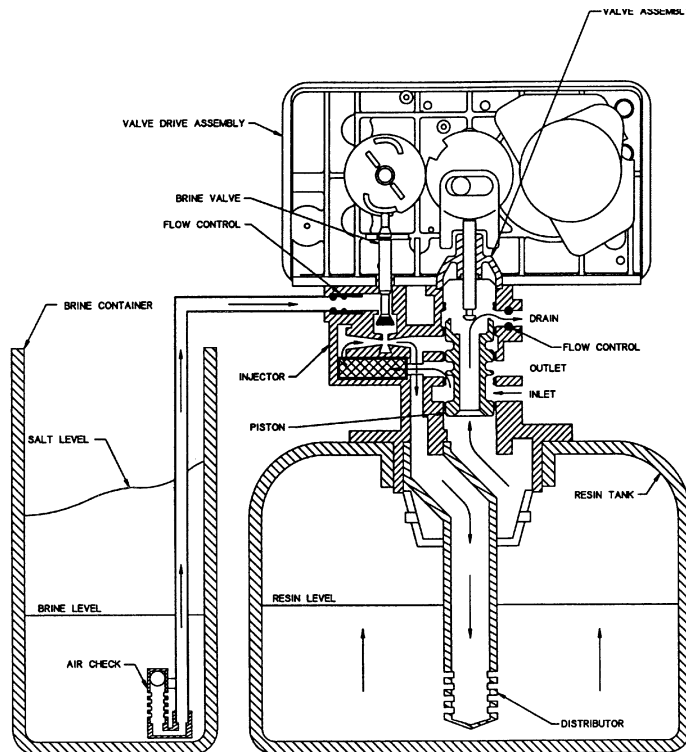

Rapid Rinse Position (Regeneration Cycle Step #3)

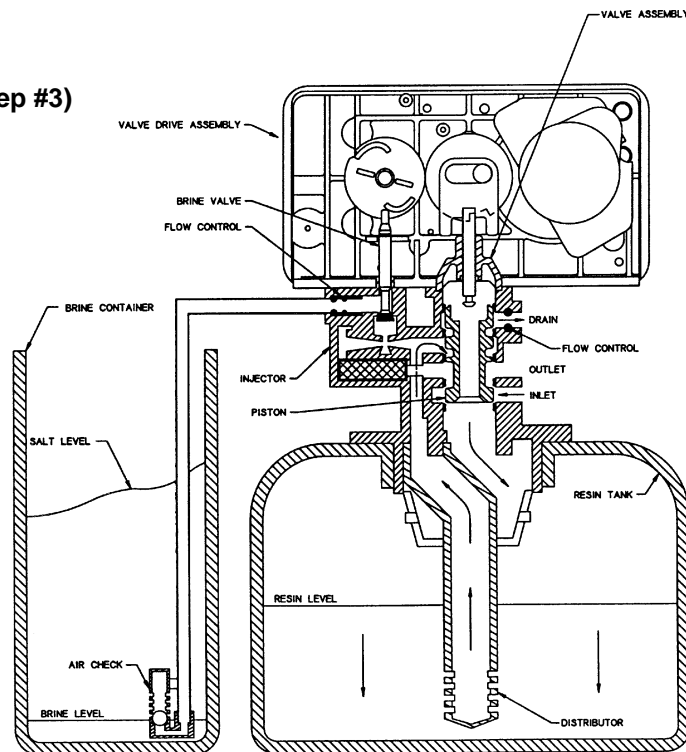

MODEL 5600SE Upflow

Water Conditioner Flow Diagrams (Upflow Brining)

Using Yellow Cycle Cam (Part No. 24598) (Cont'd.)

Brine Tank Fill Position (Regeneration Cycle Step #4)

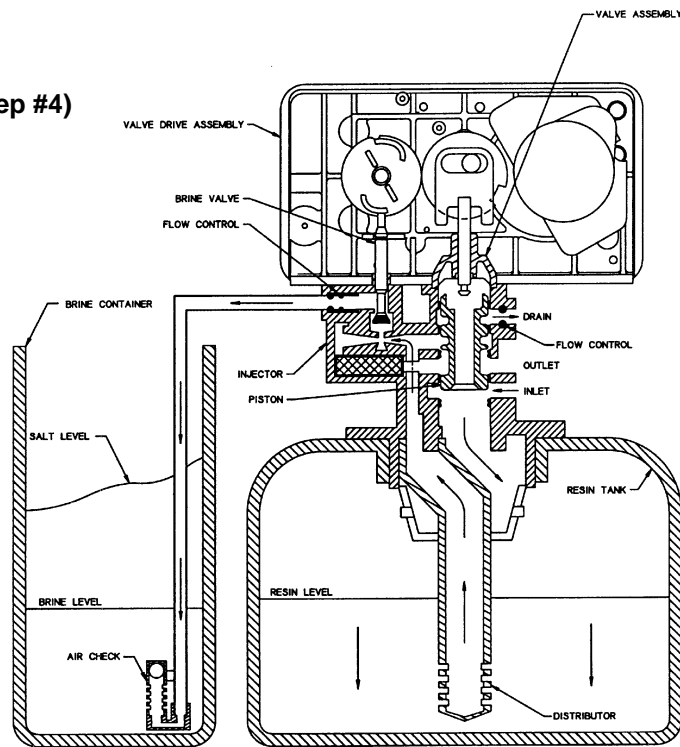

Service Position

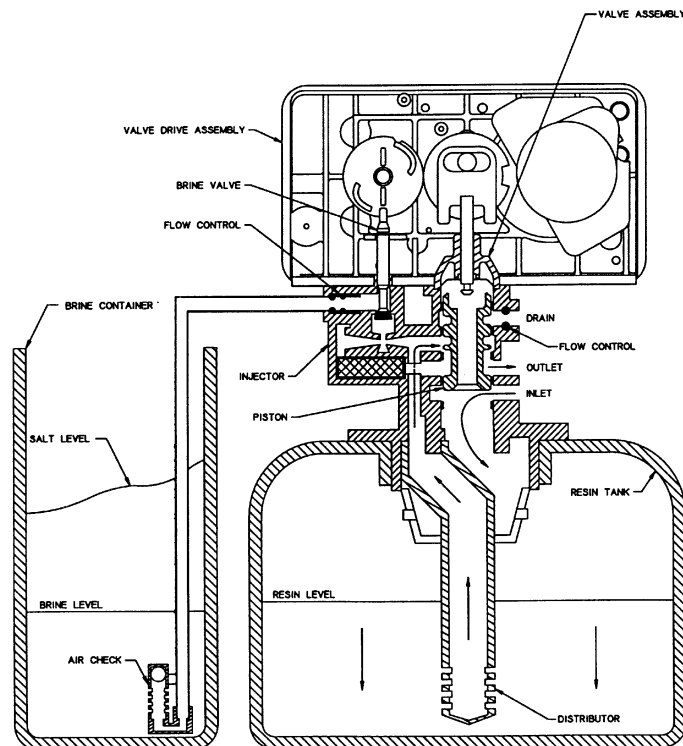

MODEL 5600SE Upflow

Water Conditioner Flow Diagrams (Upflow Brining)

Using Red Cycle Cam (Part No. 17885)

Service Position

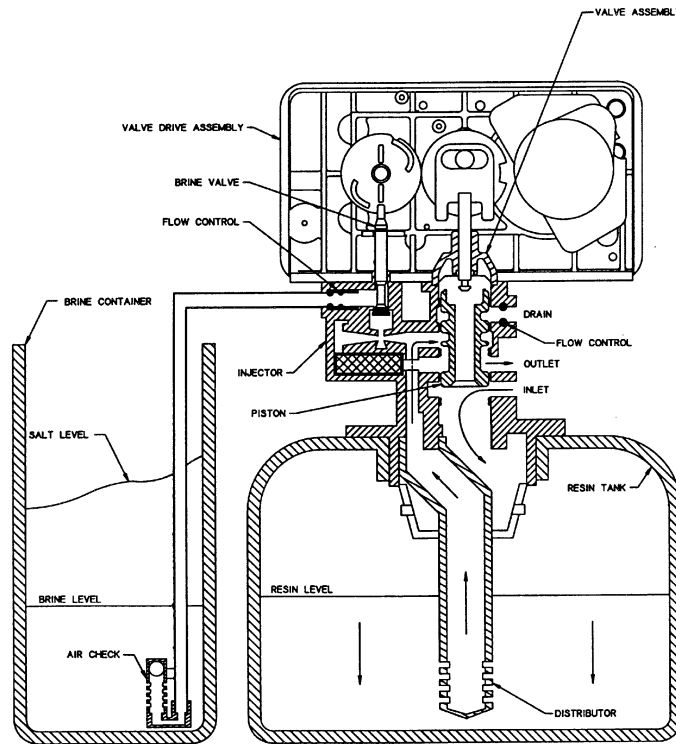

Brine/Slow Rinse Position (Regeneration Cycle Step #1)

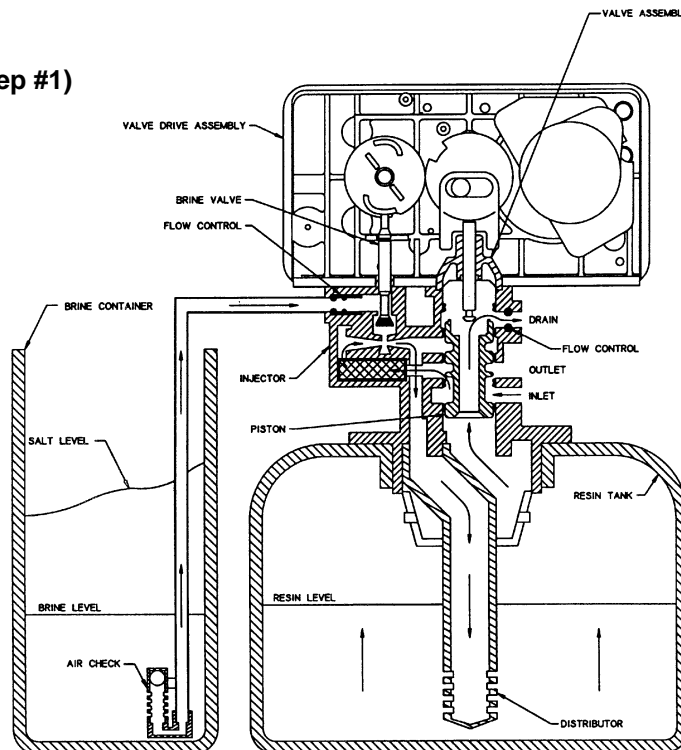

MODEL 5600SE Upflow

Water Conditioner Flow Diagrams (Upflow Brining)

Using Red Cycle Cam (Part No. 17885)

Backwash Position (Regeneration Cycle Step #2)

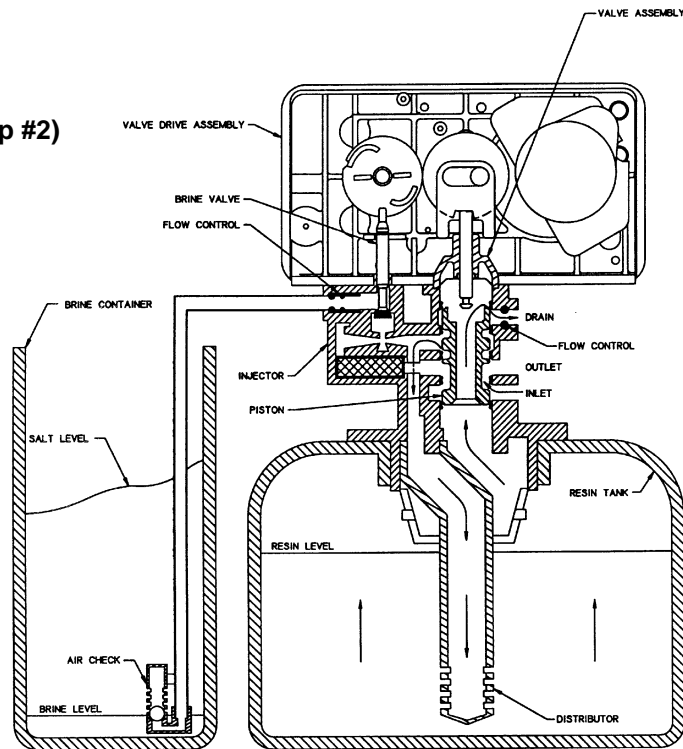

Rapid Rinse Position (Regeneration Cycle Step #3)

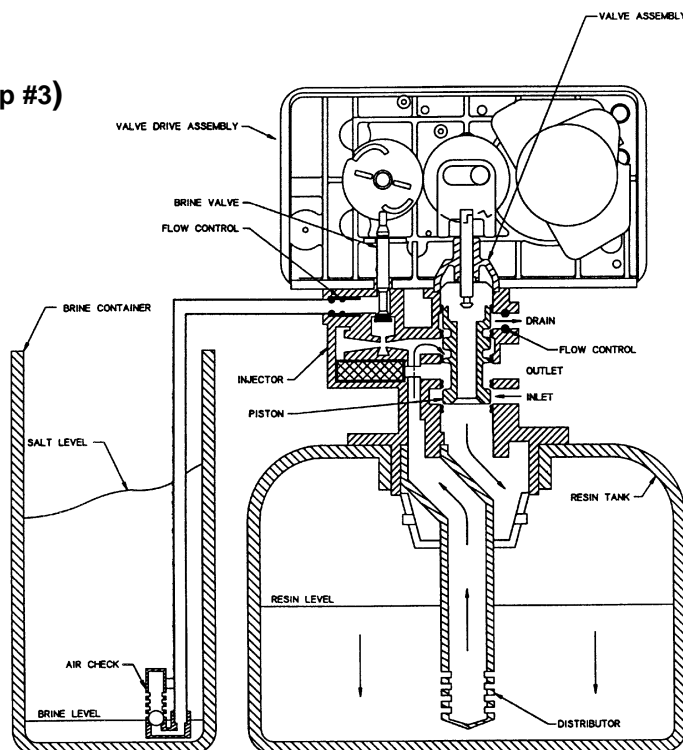

MODEL 5600SE Upflow

Water Conditioner Flow Diagrams (Upflow Brining)

Using Red Cycle Cam (Part No. 17885)

Brine Tank Fill Position (Regeneration Cycle Step #4)

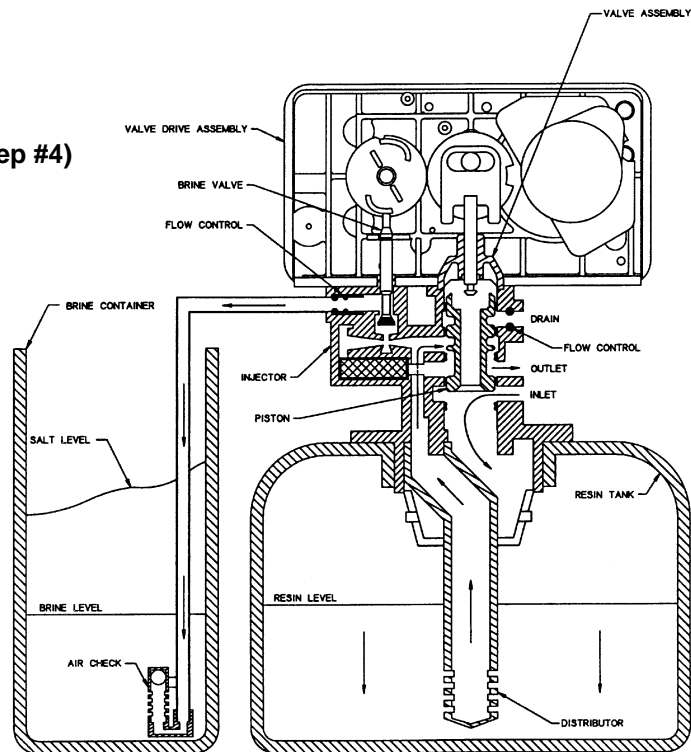

Service Position

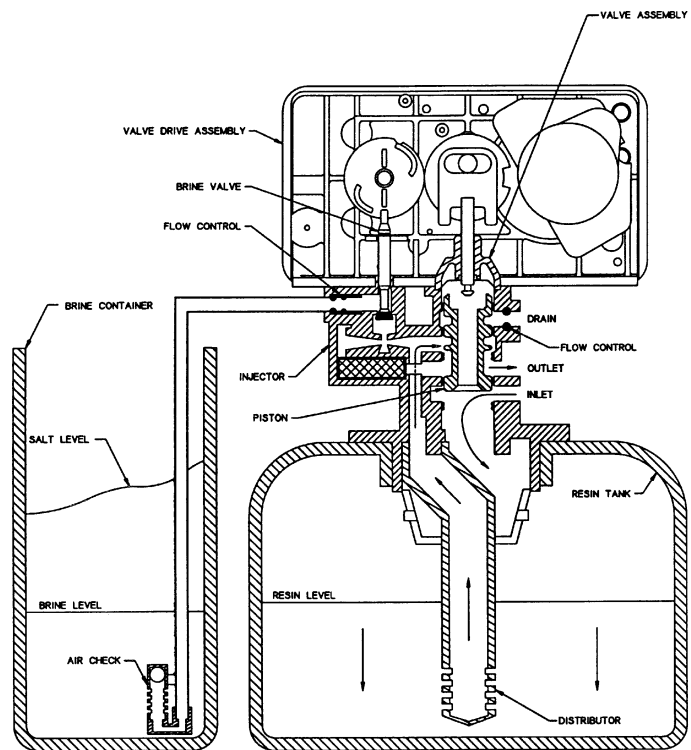

MODEL 5600SE Upflow

Valve Wiring Diagram

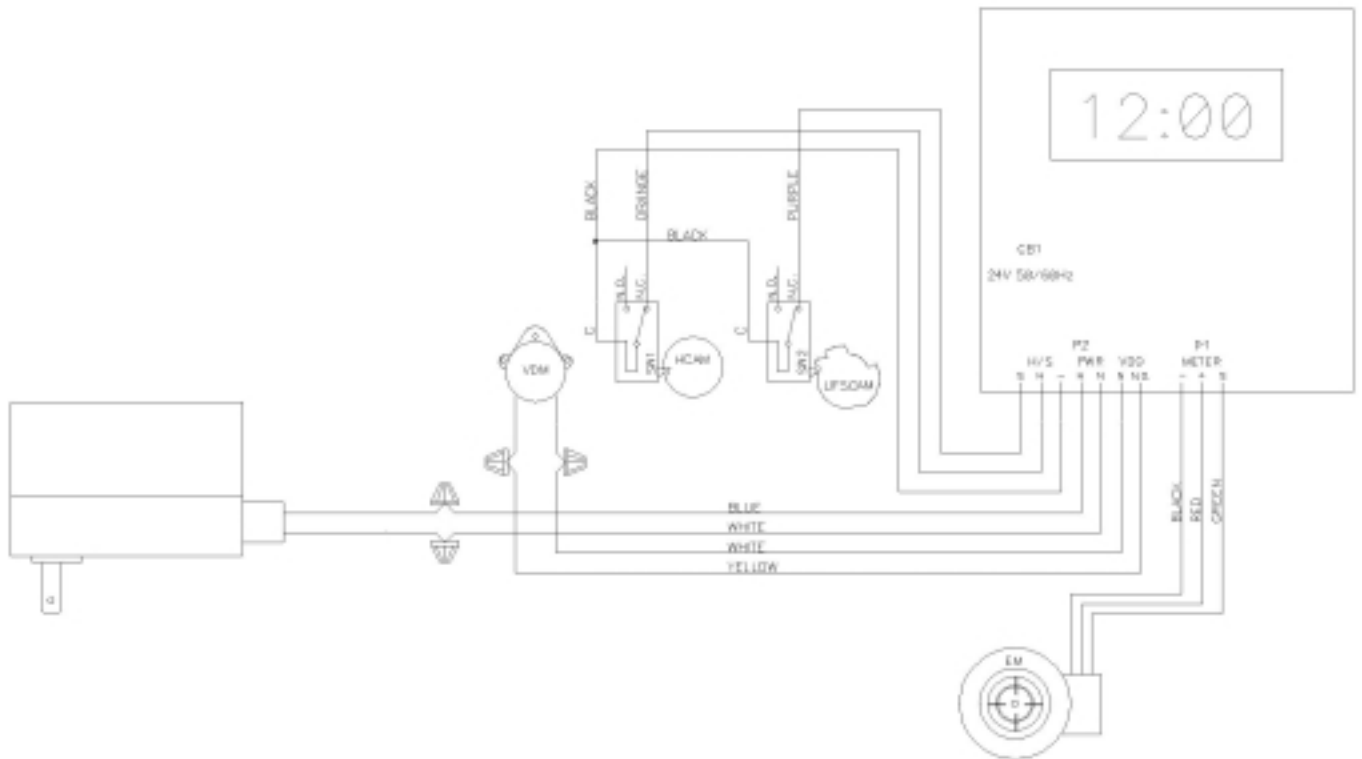

- CB1 - 5600SE Circuit Board
- VDM - Valve Drive Motor
- EM - Electronic Flow Meter (Optional)
- SW1 - Homing Switch
- SW2 - Step Switch
- HCAM - Homing Cam
- UFSCAM - Upflow Step Cam

MODEL 5600SE Upflow

Control Valve Assembly

(See opposite page for parts list)

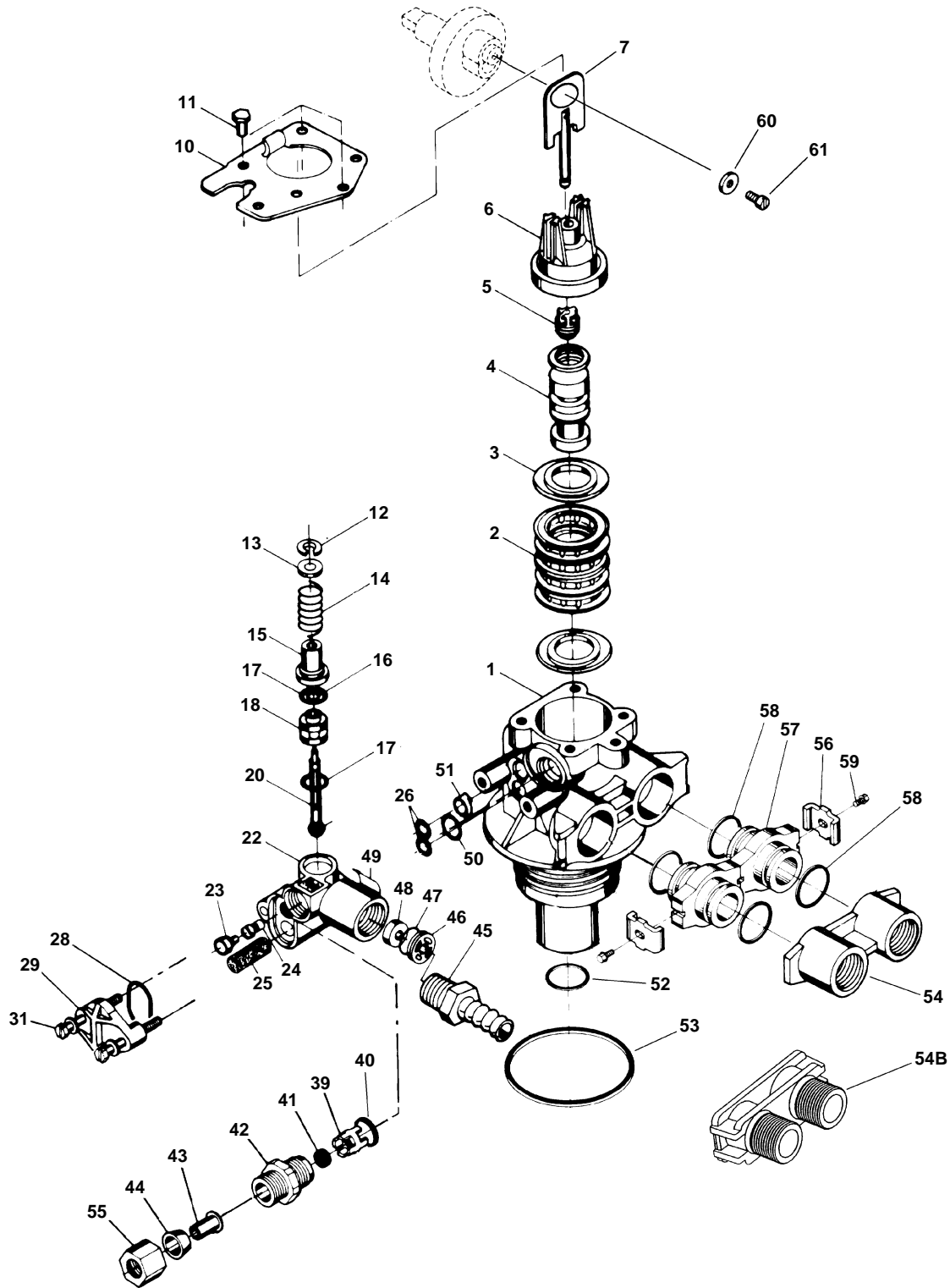

MODEL 5600SE Upflow

Control Valve Assembly

Parts List

Item No.	Quantity	Part No.	Description
1.	1	61400-31	Valve Body, Up-Flow 13/16" Distributor
	1	61400-32	Valve Body, Up-Flow 1" Distributor
2.	4	14241	Spacer
3.	5	13242	Seal
4.	1	18848	Piston - (Used with Yellow or Red Cycle Cam)
5.	1	14309	Piston Rod Retainer
6.	1	15561	End Plug Assy - White
7.	1	13001-03	Piston Rod Assembly, 6600 Up Flow
8.			Not Assigned
9.			Not Assigned
10.	1	13546	End Plug Retainer
11.	3	12473	Screw
12.	1	11981-01	Retaining Ring
13.	1	16098	Washer Brine Valve
14.	1	11973	Spring Brine Valve
15.	1	13165	Brine Valve Cap
16.	1	12550	Quad Ring
17.	2	13302	O-Ring
18.	1	13167	Spacer
19.	1	14613	Flow Straightener (Not Shown)
20.	1	13172	Brine Valve Stem
21.	1	12626	Brine Valve Seat
22.	1	13163	Injector Housing
23.	1	10913	Injector Nozzle (Specify Size)
24.	1	10914	Injector Throat (Specify Size)
25.	1	10227	Injector Screen
26.	2	13301	O-Ring Injector
28.	1	13303	O-Ring Injector Cover
29.	1	13166	Injector Cover
31.	2	13315	Screw
39.	1	13245	BLFC Button Retainer
40.	1	12977	O-Ring
41.	1		BLFC Button (Specify Size)
42.	1	13244	BLFC Fitting 3/8"
43.	3	10332	BLFC Insert 3/8"
44.	3	10330	BLFC Ferrule 3/8"
45.	1	13308	Drain Hose Barb
46.	1	13173	DLFC Button Retainer
47.	1	15348	O-Ring DLFC Retainer
48.	1		DLFC Button (Specify Size)
49.	1	13333	Injector Label
50.	1	12638	O-Ring Drain
51.	1	13497	Air Disperser
52.	1	13304	O-Ring Distributor Tube 1"
52.	1	10244	O-Ring Distributor Tube 13/16"
53.	1	12281	O-Ring, -338
54A	1	13398	Yoke, Brass, 1" NPT
	1	13708	Yoke, Brass, 3/4" NPT
54B	1	18706	Yoke, Plastic, 1" NPT
	1	18706-02	Yoke, Plastic, 3/4" NPT
55.	3	10329	BLFC Fitting Nut
*56.	2	13255	Adapter Clip
*57.	2	19228	Adapter Coupling
*58.	4	13305	O-Ring - Adapter Coupling
*59.	2	13314	Screw - Adapter Coupling
*Not used with meter controls.			
60.		1	13363Washer
61.		1	13296Screw

MODEL 5600SE Upflow

Valve Powerhead Assembly

(See opposite page for parts list)

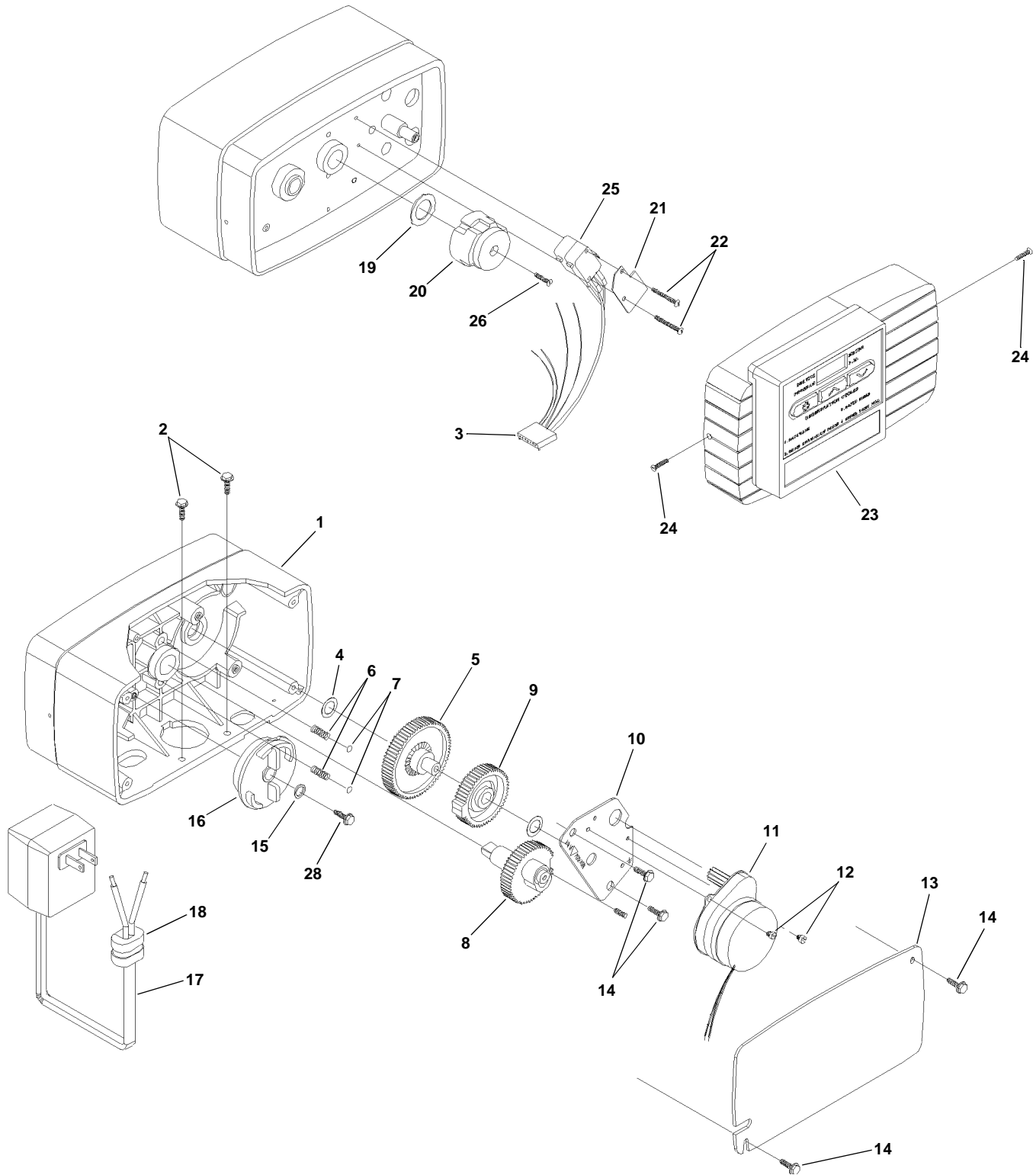

MODEL 5600SE Upflow

Valve Powerhead Assembly

Parts List

Item No.	Quantity	Part No.	Description
1.	1	26001-02	Drive Housing, Black
2.	2	12473	Screw, Drive Mount
3.	1	19474	Wire Harness, Power
4.	1	13299	Spring Washer
5.	1	13017	Idler Gear
6.	2	19080	Spring, Detent
7.	2	13300	Ball, Detent
8.	1	24958	Main Drive Gear & Shaft (Upflow Brining - White)
9.	1	23045	Drive Gear
10.	1	13175	Motor Mounting Plate
11.	1	16944	Drive Motor 2RPM 24V 50/60Hz
12.	3	11384	Screw, Motor
13.	1	13229	Back Plate
14.	4	13296	Screw, Component
15.	1	12037	Washer
16.	1	18722	Cam, Brine Valve
17.	1	19674	Transformer, 24V 9.6VA (U.S. 120V)
	1	25651	Transformer, 24V 9.6 VA (European 230V)
18.	1	13547	Strain Relief
19.	1	19079	Washer, Friction
20.	1	24598	Cycle Cam (Upflow Brining - Yellow) Backwash First
	1	17885	Cycle Cam (Upflow Brining - Red) Brine Draw/Slow Rinse First
21.	1	10302	Insulator
22.	2	17876	Screw, Microswitch
23.	1	60755-XXX	Front Panel Assembly (Specify Regen Type)
24.	2	13898	Screw, Front Panel
25.	2	10218	Microswitch
26.	1	15151	Screw, Cycle Cam
27.	4	12681	Wire Nut, Beige (Not Shown)
28.	1	40214	Screw

MODEL 5600SE Upflow

3/4" Turbine Meter Assembly

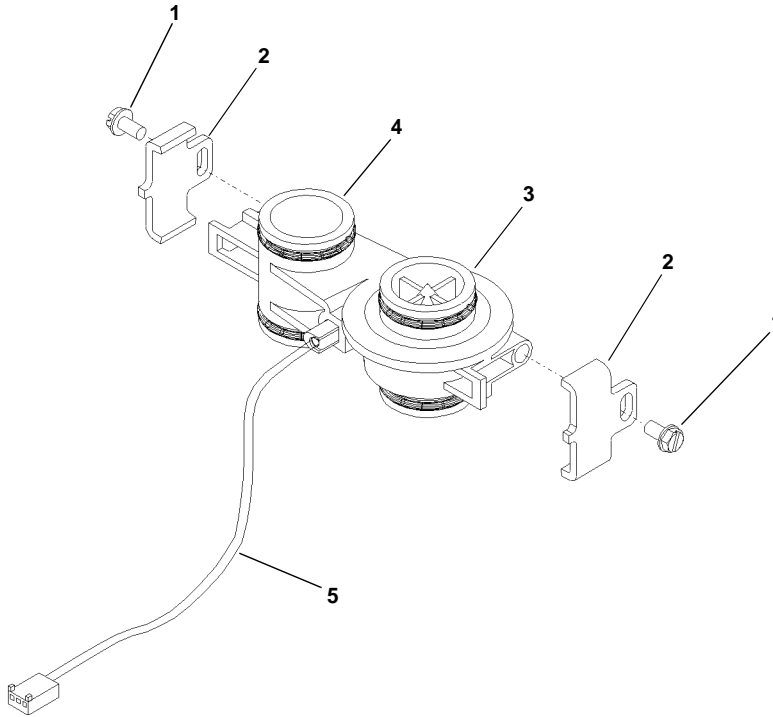

Parts List

Item No.	Quantity	Part No.	Description
1.....	2.....	13314.....	Screw, Hex Washer, 8-18 x 5/8
2.....	2.....	19569.....	Clip, Flow Meter
3.....	1.....	19797.....	Meter Body Assembly, 3/4" Turbine
4.....	4.....	13305.....	O-Ring, -119
5.....	1.....	19791-01.....	Harness Assembly, Flow Meter
6.....	1.....	14613.....	Flow Straightener (Not Shown)

MODEL 5600SE Upflow

By-pass Valve Assembly, Plastic

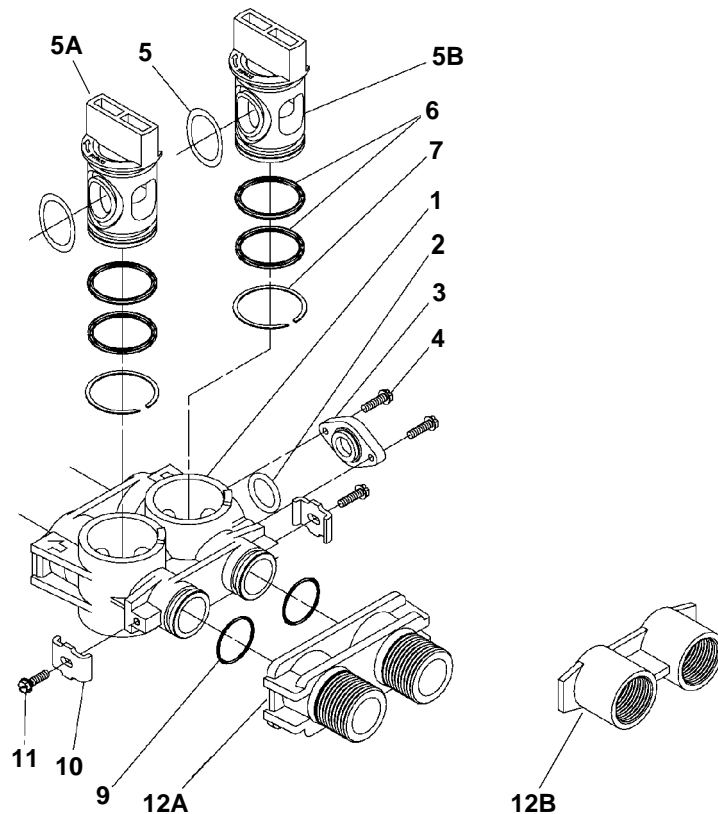

Parts List

Item No.	Quantity	Part No.	Description
1	1	19723	By-Pass Valve Body, Plastic
2	1	11183	O-Ring, -015
3	1	19724	Cap, By-Pass
4	2	17512	Screw, Hex Washer Head, #6-24 x 3
5A	1	17820	Plug, By-Pass, Inlet
5B	1	17820-01	Plug, By-Pass, Outlet (White)
6	4	18661	O-Ring, -218
7	2	18662	Retaining Ring
8	2	18660	O-Ring
9	2	13305	O-Ring, -119
10	2	13255	Clip, Mounting
11	2	13314	Screw, Hex Washer Head, 8-18 x 5/8
12A	1	18706	Yoke, Plastic, 1" NPT
		18706-02	Yoke, Plastic, 3/4" NPT
12B	1	13708	Yoke, Brass, 3/4" NPT
	1	13708NP	Yoke, 3/4" NPT Nickel Plated
	1	13398	Yoke, Brass, 1" NPT
	1	13398NP	Yoke, 1" NPT Nickel Plated

MODEL 5600SE Upflow

By-pass Valve Assembly, Brass

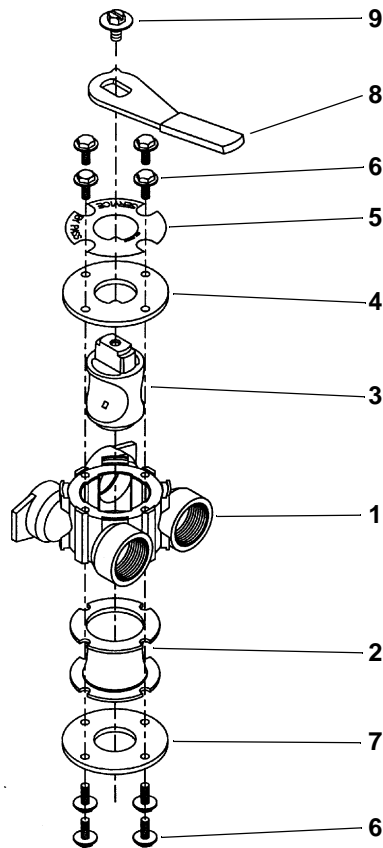

Parts List

Item No.	Quantity	Part No.	Description
1	1	17290	By-Pass Valve Body, 3/4"
	1	17290NP	By-Pass Valve Body, 3/4" Nickel Plate
	1	13399	By-Pass Valve Body, 1"
	1	13399NP	By-Pass Valve Body, 1", Nickel Plate
2	1	11726	Seal, By-Pass
3	1	11972	Plug, By-Pass
4	1	11978	Side Cover
5	1	13604-01	Label
6	8	15727	Screw
7	1	11986	Side Cover
8	1	11979	Lever, By-Pass
9	1	11989	Screw, Hex Head, 1/4-14

MODEL 5600SE Upflow

2300 Safety Brine Valve

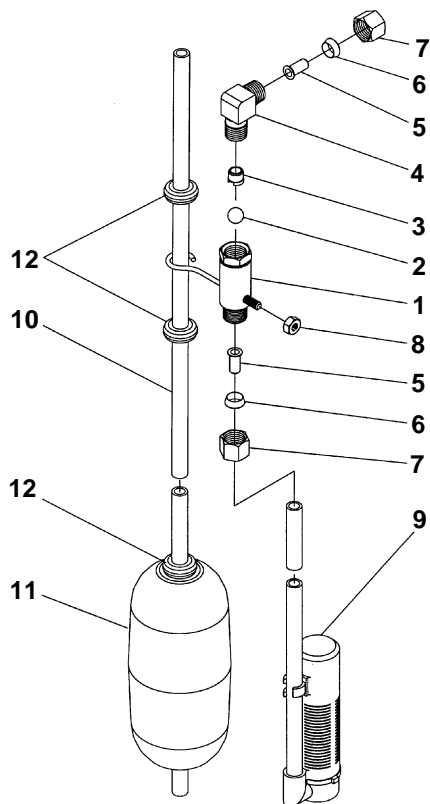

Parts List

Item No.	Quantity	Part No.	Description
1	1	60027-00	2300 Safety Brine Valve Body
2	1	10138	Ball, 3/8"
3	1	11566	Bull Stop
4	1	10328	Elbow, 1/4 x 1/4 T
5	2	10332	Insert, 3/8
6	2	10330	Sleeve, 3/8
7	2	10329	Tube Nut, 3/8
8	1	10186	Nut, Hex, 10-32, Nylon
9	1	60002	#500 Air Check
10	1	10149	Float Rod, 30"
11	1	10700	Float Assembly, Blue/White
12	4	10150	Grommet

MODEL 5600SE Upflow

2310 Safety Brine Valve

(See Opposite Page for Parts List)

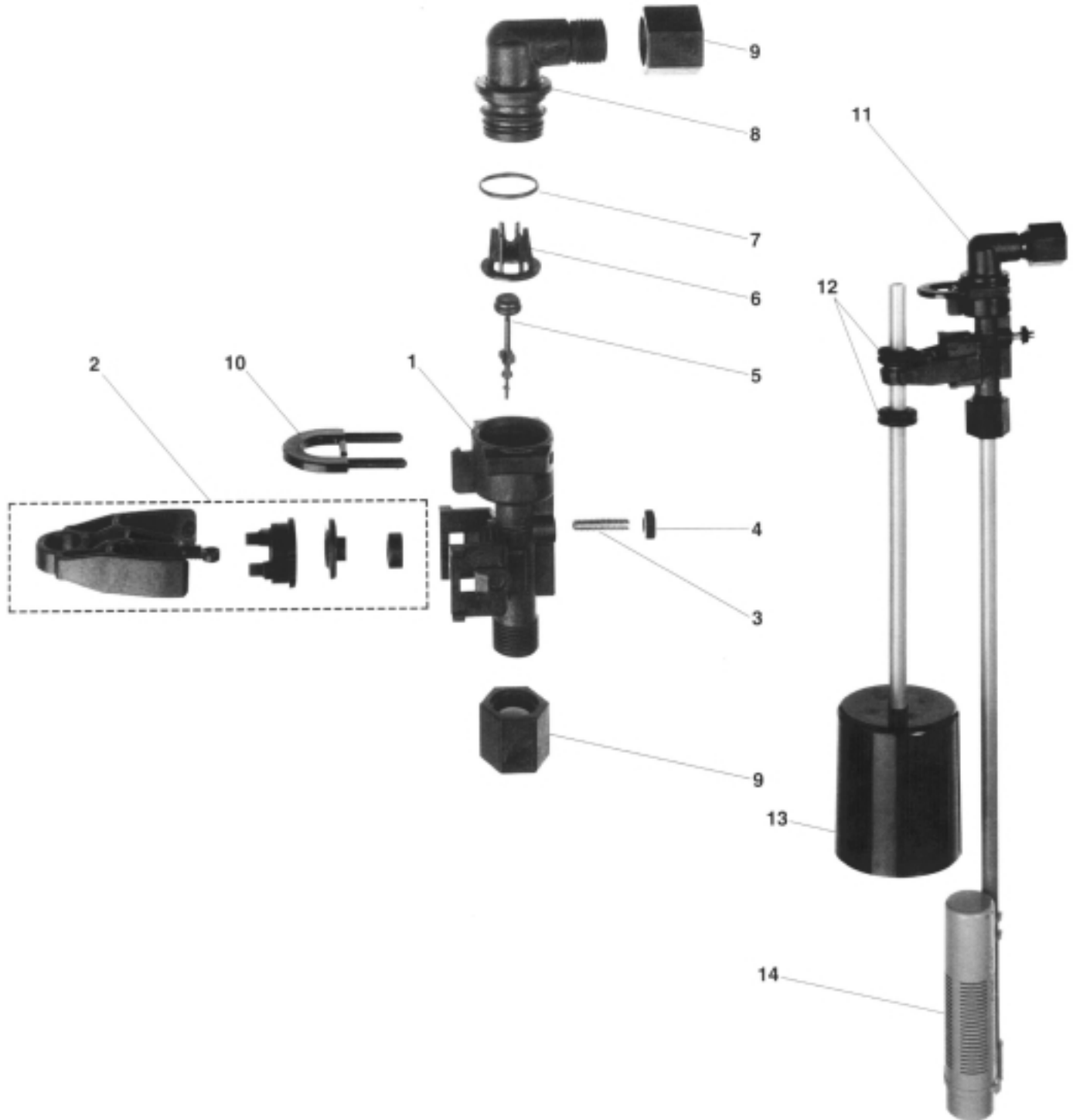

MODEL 5600SE Upflow

2310 Safety Brine Valve

Parts List

Item No.	Quantity	Part No.	Description
1.....	1	19645	Safety Brine Valve Body
2.....	1	19803	Safety Brine Valve Arm Assembly
3.....	1	19804	Stud, 10-24
4.....	1	19805	Nut, 10-24
5.....	1	19652-01.....	Poppet & Seal
6.....	1	19649	Flow Dispenser
7.....	1	11183	O-Ring, -017
8.....	1	19647	Elbow, Safety Brine Valve
9.....	2	19625	Nut Assembly, 3/8
10	1	18312	Retaining Clip
11	1	60014	Safety Brine Valve, 2310 (includes items 1-10)
12	2	10150	Grommet (included with item 13)
13	1	60068	Float Assembly, 2310
14	1	60002	500 Air Check Assembly

MODEL 5600SE Upflow

Service Instructions

A. TO REPLACE TIME BRINE VALVE, INJECTORS, AND SCREEN

1. Turn off water supply to conditioner:
 - a. If the conditioner installation has a three valve by-pass system, first open the valve in the by-pass line, then close the valves at the conditioner inlet and outlet.
 - b. If the conditioner has an integral by-pass valve, put it in the by-pass position.
 - c. If there is only a shut-off valve near the conditioner inlet, close it.
2. Relieve water pressure in the conditioner by stepping the control into the backwash position momentarily. Return the control to the service position.
3. Unplug electrical cord from outlet.
4. Disconnect brine tube and drain line connections at the injector body.
5. Remove the two injector body mounting screws. The injector and brine module can now be removed from the control valve. Remove and discard brine body O-rings.
- 6A. To replace brine valve.
 1. Pull brine valve from injector body, also remove and discard O-ring at bottom of brine valve hole.
 2. Apply silicone lubricant to new O-ring and reinstall at bottom of brine valve hole.
 3. Apply silicone lubricant to O-ring on new valve assembly and press into brine valve hole, shoulder on bushing should be flush with injector body.
- 6B. To replace injectors and screen.
 1. Remove injector cap and screen, discard O-ring. Unscrew injector nozzle and throat from injector body.
 2. Screw in new injector throat and nozzle, be sure they are sealed tightly. Install a new screen.
 3. Apply silicone lubricant to new O-ring and install around oval extension on injector cap.
7. Apply silicone lubricant to three new O-rings and install over three bosses on injector body.
8. Insert screws with washers thru injector cap and injector. Place this assembly thru hole in timer housing and into mating holes in the valve body. Tighten screws.
9. Disconnect brine tube and drain line.
10. Return by-pass or inlet valving to normal service position. Water pressure should now be applied to the conditioner, and any by-pass line shut off.

11. Check for leaks at all seal areas. Check drain seal with the control in the backwash position.
12. Plug electrical cord into outlet.
13. Set time of day and cycle the control valve manually to assure proper function. Make sure control valve is returned to the service position.
14. Take sure there is enough salt in the brine tank.
15. Start regeneration cycle manually if water is hard.

B. TO REPLACE TIMER

1. Follow Steps A.1 through A.3 .
2. Remove the control valve back cover. Remove the control valve front cover. Disconnect the meter dome signal wire from the front cover and feed it back through the control.
3. Remove screw and washer at drive yoke. Remove timer mounting screws. The entire timer assembly will now lift off easily.
4. Put new timer on top of valve. Be sure drive pin on main gear engages slot in drive yoke.
5. Replace timer mounting screws. Replace screw and washer at drive yoke. Replace meter signal wire.
6. Return by-pass or inlet valving to normal service position. Water pressure should now be applied to the conditioner, and any by-pass line shut off.
7. Replace the control valve back cover.
8. Follow Steps A.12 through A.15 .

C. TO REPLACE PISTON ASSEMBLY

1. Follow Steps A.1 through A.3 .
2. Remove the control valve back cover. Remove the control valve front cover. Disconnect the meter dome signal wire from the front cover and feed it back through the control.
3. Remove screw and washer at drive yoke. Remove timer mounting screws. The entire timer assembly will now lift off easily. Remove end plug retainer plate.
4. Pull upward on end of piston yoke until assembly is out of valve.
5. Inspect the inside of the valve to make sure that all spacers and seals are in place, and that there is no foreign matter that would interfere with the valve operation.
6. Take new piston assembly as furnished and push piston into valve by means of the end plug. Twist yoke carefully in a clockwise direction to properly align it with drive gear. Replace end plug retainer plate.

MODEL 5600SE Upflow

Service Instructions (Cont'd.)

7. Place timer on top of valve. Be sure drive pin on main gear engages slot in drive yoke.
8. Replace timer mounting screws. Replace screw and washer at drive yoke.
9. Return by-pass or inlet to normal service position. Water pressure should now be applied to the conditioner, and any by-pass line shut off.
10. Replace the control valve back cover.
11. Follow Steps A.12 through A.15 .

D. TO REPLACE SEALS AND SPACERS

1. Follow Steps A.1 through A.3 .
2. Remove the control valve back cover. Remove the control valve front cover. Disconnect the meter dome signal wire from the front cover and feed it back through the control.
3. Remove screw and washer at drive yoke. Remove timer mounting screws. The entire timer assembly will now lift off easily. Remove end plug retainer plate.
4. Pull upward on end of piston rod yoke until assembly is out of valve. Remove and replace seals and spacers.
5. Take piston assembly and push piston into valve by means of the end plug. Twist yoke carefully in a clockwise direction to properly align it with drive gear. Replace end plug retainer plate.
6. Place timer on top of valve. Be sure drive pin on main gear engages slot in drive yoke.
7. Replace timer mounting screws. Replace screw and washer at drive yoke.
8. Return by-pass or inlet valving to normal service position. Water pressure should now be applied to the conditioner, and any by-pass line shut off.
9. Replace the control valve back cover.
10. Follow Steps A.12 through A.15 .

E. TO REPLACE METER

1. Follow Steps A.1 through A.3 .
2. Remove screw holding signal wire from meter dome.
3. Remove two screws and clips at by-pass valve or yoke. Pull resin tank away from plumbing connections.
4. Remove two screws and clips at control valve.

Pull meter module out of control valve.

5. Apply silicone lubricant to four new O rings and assemble to four ports on new meter module.
6. Assemble meter to control valve. Note, meter portion of module must be assembled at valve outlet.
7. Attach two clips and screws at control valve. Be sure clip legs are firmly engaged with lugs.
8. Push resin tank back to the plumbing connections and engage meter ports with by-pass valve or yoke.
9. Attach two clips and screws at by-pass valve or yoke. Be sure clip legs are firmly engaged with lugs.
10. Return by-pass or inlet valving to normal service position. Water pressure should now be applied to the conditioner, and any by-pass line shut off.
11. Check for leaks at all seal areas.
12. Connect meter dome signal wire.
13. Follow Steps A.12 through A.15 .

F. TO REPLACE METER COVER AND/OR IMPELLER

1. Follow Steps A.1 through A.3 .
2. Remove screw holding signal wire from meter dome.
3. Remove four screws on cover.
4. Lift cover off of meter module, discard O ring.
5. Remove and inspect impeller for gear or spindle damage, replace if necessary.
6. Apply silicone lubricant to new O-ring and assemble to the smallest diameter on meter cover.
7. Assemble cover to meter module. Be sure impeller spindle enters freely into cover. Press firmly on cover and rotate if necessary to assist in assembly.
8. Replace four screws and tighten.
9. Return by-pass or inlet valving to normal service position. Water pressure should now be applied to the conditioners, and any by-pass shut off.
10. Check for leaks at all seal areas.
11. Connect meter dome signal wire.
12. Follow Steps A.12 through A.15 .

MODEL 5600SE Upflow

Service Instructions (Cont'd.)

PROBLEM	CAUSE	CORRECTION
1. Softener Fails To Regenerate.	<ul style="list-style-type: none"> A. Electrical Service to Unit has been Interrupted. B. Timer is not Operating Properly. C. Defective Valve Drive Motor. D. Timer Programming Bad (Improper Programming). 	<ul style="list-style-type: none"> A. Assure Permanent Electrical Service (Check Fuse, Plug, Pull Chain or Switch). B. Replace Timer. C. Replace Drive Motor. D. Check Programming and Reset as Needed.
2. Softener Delivers Hard Water.	<ul style="list-style-type: none"> A. By-Pass Valve is Open. B. No Salt in Brine Tank. C. Injectors or Screen Plugged. D. Insufficient Water Flowing into Brine Tank. E. Hot Water Tank Hardness. F. Leak at Distributor Tube. G. Internal Valve Leak H. Flow Meter Jammed. I. Flow Meter Cable Disconnected or Not Plugged into Meter. J. Improper Programming. 	<ul style="list-style-type: none"> A. Close By-Pass Valve. B. Add Salt to Brine Tank and Maintain Salt Level Above Water Level. C. Replace Injectors and Screen. D. Check Brine Tank Fill Time and Clean Brine Line flow if Plugged. E. Repeated Flushings of the Hot Water Tank is Required. F. Make Sure Distributor Tube is not Cracked. Check O-Ring and Tube Pilot. G. Replace Seals and Spacers and/or Piston. H. Remove obstruction from flow meter. I. Check Meter Cable Connection to Timer and Meter. J. Reprogram the control to the Proper Regeneration Type, Inlet Water Hardness, Capacity or Flow Meter Size.
3. Unit Uses Too Much Salt.	<ul style="list-style-type: none"> A. Improper Salt Setting. B. Excessive Water in Brine Tank. C. Improper Programming. 	<ul style="list-style-type: none"> A. Check Salt Usage and Salt Setting. B. See Problem No. 7. C. Check Programming and Reset as Needed.
4. Loss of Water Pressure.	<ul style="list-style-type: none"> A. Iron Buildup in Line to Water Conditioner. B. Iron Buildup in Water Conditioner. C. Inlet of Control Plugged due to Foreign Material Broken Loose from Pipes by Recent Work Done on Plumbing System. 	<ul style="list-style-type: none"> A. Clean Line to Water Conditioner. B. Clean Control and Add Resin Cleaner to Resin Bed. Increase Frequency of Regeneration. C. Remove Piston and Clean Control.
5. Loss of Resin Through Drain Line.	<ul style="list-style-type: none"> A. Air in Water System. B. Drain Line Flow Control is too large. 	<ul style="list-style-type: none"> A. Assure that Well System has Proper Air Eliminator control Check for Dry Well Condition. B. Ensure Drain Line Flow Control is Sized Correctly.

MODEL 5600SE Upflow

Service Instructions (Cont'd.)

PROBLEM	CAUSE	CORRECTION
6. Iron in Conditioned Water.	<ul style="list-style-type: none"> A. Fouled Resin Bed. B. Iron Content Exceeds Recommended Parameters. 	<ul style="list-style-type: none"> A. Check Backwash, Brine Draw and Brine Tank Fill. Increase Frequency of Regeneration. Increase Backwash Time. B. Add Iron Removal from Filter or System.
7. Excessive Water in Brine Tank.	<ul style="list-style-type: none"> A. Plugged Drain Line Flow Control. B. Brine Valve Failure. C. Improper Programming. 	<ul style="list-style-type: none"> A. Clean Flow Control. B. Replace Brine Valve. C. Check Programming and Reset as Needed.
8. Salt Water in Service Line.	<ul style="list-style-type: none"> A. Plugged Injector System. B. Timer not Operating Properly. C. Foreign Material in Brine Valve. D. Foreign Material in Brine Line Flow Control. E. Low Water Pressure. F. Improper Programming. 	<ul style="list-style-type: none"> A. Clean Injector and Replace Screen. B. Replace Timer. C. Clean or Replace Brine Valve. D. Clean Brine Line Flow Control. E. Raise Water Pressure. F. Check Programming and Reset as Needed.
9. Softener Fails to Draw Brine.	<ul style="list-style-type: none"> A. Drain Line Flow Control is Plugged. B. Injector is Plugged. C. Injector Screen Plugged. D. Line Pressure is too Low. E. Internal Control Leak. F. Improper Programming. G. Timer not Operating Properly. 	<ul style="list-style-type: none"> A. Clean Drain Line Flow Control. B. Clean or Replace Injectors. C. Replace Screen. D. Increase Line Pressure (Line Pressure must be at Least 20 PSI at all Times.) E. Change Seals and Spacers and/or Piston Assembly. F. Check Programming and Reset as Needed. G. Replace Timer.
10. Control Cycles Continuously.	<ul style="list-style-type: none"> A. Timer not Operating Properly. B. Faulty Microswitches and or Harness. C. Faulty Cycle Cam Operation. 	<ul style="list-style-type: none"> A. Replace Timer. B. Replace Faulty Microswitch or Harness. C. Replace Cycle Cam or Reinstall.
11. Drain Flows Continuously.	<ul style="list-style-type: none"> A. Foreign Material in Control. B. Internal Control Leak. C. Control Valve Jammed in Brine or Backwash Position. D. Timer Motor Stopped or Jammed. E. Timer not Operating Properly. 	<ul style="list-style-type: none"> A. Remove Piston Assembly and Inspect Bore, Remove Foreign Material & Check Control in Various Regeneration Positions. B. Replace Seals and/or Piston Assembly. C. Replace Piston and Seals and Spacers. D. Replace Timer Motor and Check all Gears for Missing Teeth. E. Replace Timer.

MODEL 5600SE Upflow

Service Assemblies

60022-25	BLFC .25 GPM	60626	5600SE Meter Assembly
60022-50	BLFC .50 GPM		For Illustration and Parts List, See Page 20
60022-100	BLFC 1.0 GPM	60755-021	5600SE Front Panel Assembly
	For Illustration, See Page 16		Black, Backwash First Label, DF/UF
			For Illustration, See Page 18
	12094	60755-121	5600SE Front Panel Assembly
	Flow Washer .25 GPM		Black, Brine First Label, UF
	12095		For Illustration, See Page 18
	Flow Washer .50 GPM	60756-0212	5600SE Metered Power Head Assembly
	12097		Black, Backwash First Label, UF
	Flow Washer 1.0 GPM		For Illustration, See Page 18
1	12977	60756-1212	5600SE Metered Power Head Assembly
	O-Ring, - 015		Black, Brine Draw First Label, UF
1	13244		For Illustration, See Page 18
	Adapter, BLFC	60757-0212	5600SE Timeclock Power Head Assembly
1	13245		Black, Backwash First Label, UF
	Retainer, BLFC		For Illustration, See Page 18
	60032	60757-1212	5600SE Timeclock Power Head Assembly
	Brine Valve		Black, Brine Draw First Label, UF
	For Illustration, See Page 16		For Illustration, See Page 18
1	11973		
	Spring, Brine Valve		
1	11981-01		
	Retaining Ring		
1	12550		
	Quad Ring, -009		
1	13165		
	Cap, Brine Valve		
1	13167		
	Spacer, Brine Valve		
2	13302		
	O-Ring, -014		
1	16098		
	Washer, Plain, Nylon		
1	13172		
	Brine Valve Stem		
1	12626		
	Seat, Brine Valve		
	60040		
	By Pass, 3/4" Brass		
	60040NP		
	By Pass, 3/4" Nickel		
	60041		
	By Pass, 1" Brass		
	60041NP		
	By Pass, 1", Nickel		
	For Illustration and Parts		
	List, See Page 22.		
	60049		
	Bypass, Plastic, 3/4"		
	For Illustration and Part List,		
	See Page 21		
	60102-62		
	5600SE Piston Assembly -		
	Upflow		
	For Illustration, See Page 16		
1	14309		
	Piston Rod Retainer		
1	13001-03		
	Piston Rod Assembly		
1	15561		
	End Plug Assy. - White		
1	18848		
	Piston, Upflow		
	60125		
	5600SE Seal and Spacer Kit		
	For Illustration and Parts List,		
	See Pages 16 and 17		
5	13242		
	Seal		
4	14241		
	Spacer		
	60084 - Injector - Module Assembly		
	(Specify Inj. Number, D.L.F.C.		
	Size, B.L.F.C. Size)		
	For Illustration and Parts List,		
	See Pages 16 and 17		

